

INSTRUCTION MANUAL

SLS HIGHOUTPUT

LS87SAT SPEAKER



Introduction

Thank you for purchasing **SLS HIGHOUTPUT** Speakers. When properly installed, these speakers will provide you with years of outdoor entertainment pleasure. To get the most out of your new speakers, please read this manual thoroughly before you begin installation.

Box Contents

SLS HIGHOUTPUT Satellite box contains:

- (1) Satellite speaker
- (2) Silicone filled wire nuts

Satellite Location Selection

The Sonance Landscape Series is designed to deliver a seamless, evenly dispersed sound field in an 'open air' environment. An array of multiple satellite speakers and subwoofers should be strategically placed to minimize 'hot spots' and 'nulls' as you move around the outdoor entertainment area. See Figure 1.

As a general guideline, (1) satellite will cover about 250 square feet of listening area

Select locations for the satellites that are as close as possible to the same distance from the main listening area. When possible use high and low locations to centralize the acoustic stage. See figure 2

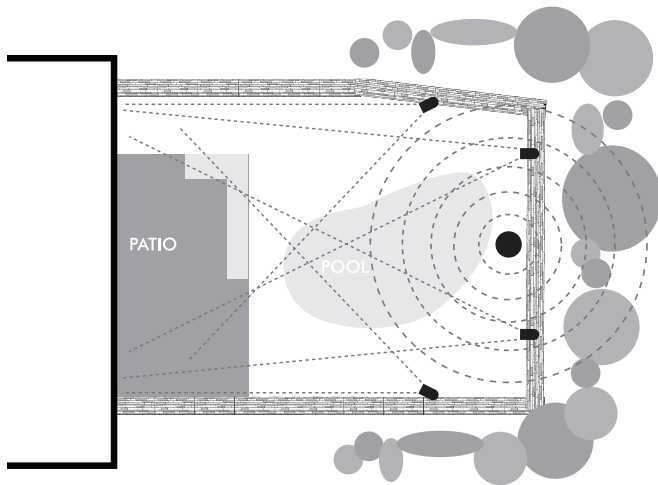

Figure 1

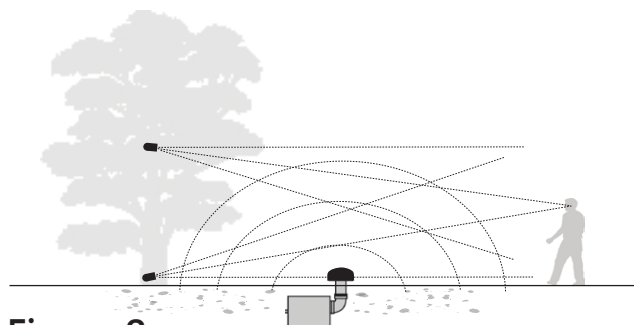
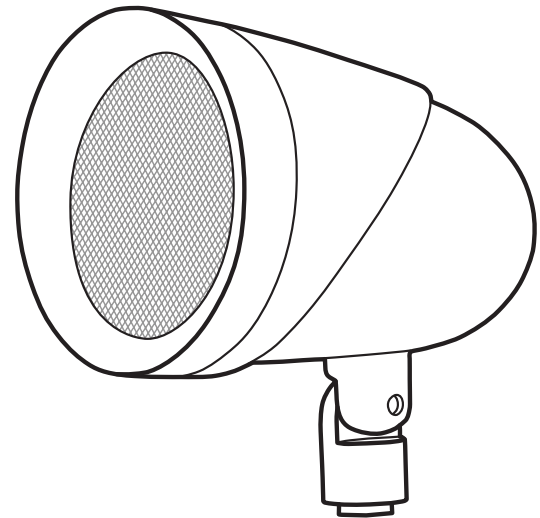

Figure 2



LS87SAT Speaker
Patent Pending

Amplifier Power Planning

The maximum number of satellites and subwoofers that can be used in a system will depend on the quantity of amplifier power available.

Before beginning an installation use the chart below to calculate the amplifier power your installation will require. Multiple amplifiers may be required in large installations.

Wattage Calculator

Model	Qty. Ch.1	Qty. Ch.2	x	Watts	Total Ch.1	Total Ch.2
LS87SAT			x	50		
LS15SUB*			x	400		
				Sub Total		
				20% Head Room		
TOTAL WATTAGE						

*The LS15SUB is a dual voice coil, single-stereo subwoofer. Each voice coil draws 200 watts, for a combined total of 400 watts. The LS15SUB requires a 4-conductor wire to connect both it's left and right channel inputs.

Amplifier Selection

For systems up to 500w per channel use the CROWN CDI 1000
 For systems up to 800w per channel use the CROWN CDI 2000
 For systems up to 1000w per channel use the CROWN CDI 4000

Satellite Installation

70 volt audio systems allow for speakers to be daisy chained together. In a typical system with one zone of audio you simply run a stereo or 4 conductor wire from the amplifier to the closest speaker. Once you have designated your first speaker as either left or right, continue alternating the wires between the left and right channels creating a daisy chain of stereo satellites. The subwoofer can be wired anywhere in the chain. See figure 4.

Note: Sonance strongly recommends the use of 14 gauge or larger direct burial grade wire.

Caution: The amplifier should not be connected to AC power until all connections are completed. High power 70 volt amplifiers present a serious shock hazard. Do not connect speaker wires to the amplifier until all other connections are completed.

- Once locations have been established, choose the appropriate mounting accessories for the project. **PLEASE NOTE:** Always use a #3 Phillips head screwdriver when fine tuning the height adjustment screw.
 - For applications on flat surfaces, such as the side of a building or structure, use the SM1 Round Surface Mount. See Instruction Manual included with accessory for precise instructions
 - For placement directly into the ground, use the GP19 PVC Ground Post
 - For in-tree mounting, use the TSMJB Tree / Surface Mounting Junction Box. See Instruction Manual included with accessory for precise instructions.
- Once the accessories have been mounted at the desired locations, mount the satellites by threading the mounting shaft into the corresponding opening of the accessory.

Note: Attention must be paid to the electrical leads to avoid nicks and cuts that might short the system.

- Prepare individual leads to be connected to main leads.
- Dig a 4" – 5" deep trench to run the speaker wires in.
- Run the wire through the trench from your amplifier to the first speaker location.
- Connect the direct burial wire to each speaker wire, connections should be made with either silicone filled wire connectors or appropriate junction boxes. See figure 3.

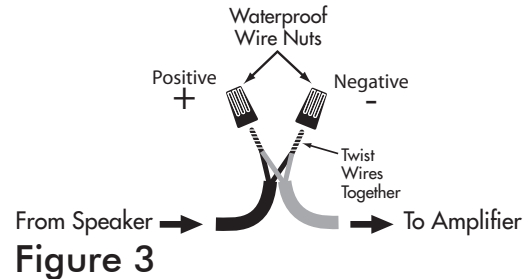

IMPORTANT: Be sure not to let any stray '+' and '-' strands touch each other. Touching strands can cause a short-circuit that could damage your amplifier.

Note: Confirm that you have connected speaker "+" to amplifier "+" and speaker "-" to amplifier "-".

- After all the speakers connections are completed, connect the wires to your amplifier. See Figure 4 for reference.
- Turn your amplifier on and test the system with your favorite music. If the speakers are operating properly, refill the wire trench and enjoy your new speakers.

SLS HIGH OUTPUT Wiring Diagram 70V



Crown CDi Series Amplifier
LS87SATs & LS15SUB

Note: The subwoofer can be connected at any point in the daisy chain.

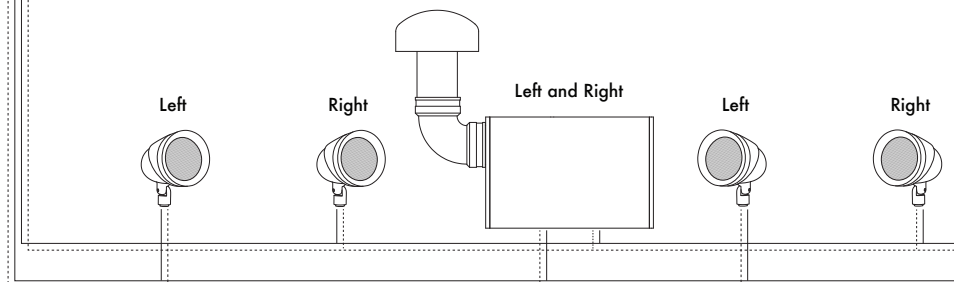

Configuration: 4 SATs to 1 SUB

Expandable →

Figure 4

Specifications

LS87SAT

Tweeter:	1.0" (25.4mm) horn-loaded PEI dome
Woofer:	6.5" (165.1mm) polypropylene cone with Santoprene® rubber surround
Frequency Response:	55Hz - 20KHz ±3dB
Power Required:	50 watts
Max SPL:	110dB @ 1 meter @ 70v/50 watts
Enclosure Material:	Non-corrosive sealed enclosure
Listening Area:	60° coverage, 10' to 50' recommended
Speaker Input:	70 volts
Dimensions:	12.2" L x 8.0" Dia (309.9mm x 203.2mm)
Shipping Weight:	8.4 lbs (3.81 kg)

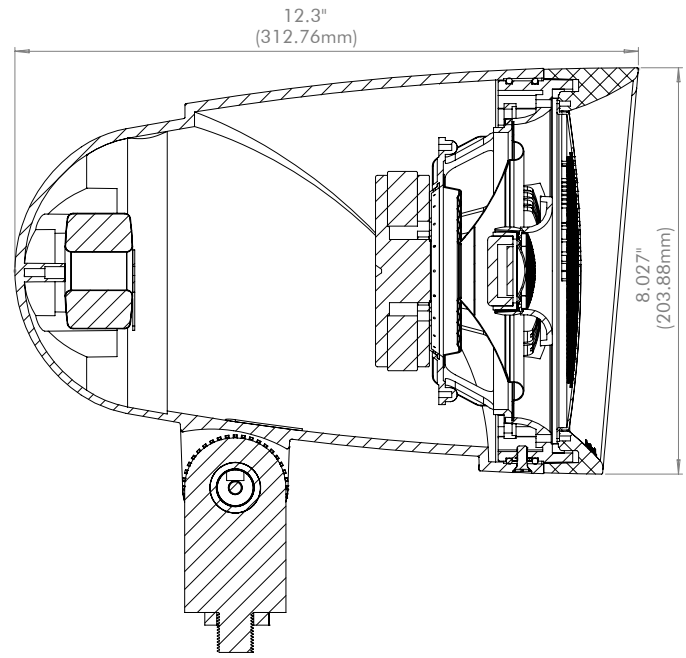

Santoprene is a registered trademark of Advanced Elastomer Systems.

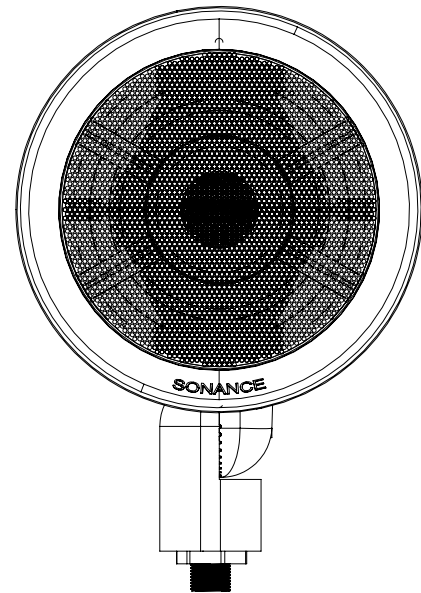

LIMITED FIVE (5) YEAR WARRANTY

Sonance warrants to the first end-user purchaser that this Sonance-brand product ("Product"), when purchased from an authorized Sonance Dealer/Distributor, will be free from defective workmanship and materials for the period stated below. Sonance will at its option and expense during the warranty period, either repair the defect or replace the Product with a new or remanufactured Product or a reasonable equivalent.

EXCLUSIONS

TO THE EXTENT PERMITTED BY LAW, THE WARRANTY SET FORTH ABOVE IS IN LIEU OF, AND EXCLUSIVE OF, ALL OTHER WARRANTIES, EXPRESS OR IMPLIED, AND IS THE SOLE AND EXCLUSIVE WARRANTY PROVIDED BY SONANCE. ALL OTHER EXPRESS AND IMPLIED WARRANTIES, INCLUDING THE IMPLIED WARRANTIES OF MERCHANTABILITY, IMPLIED WARRANTY OF FITNESS FOR USE, AND IMPLIED WARRANTY OF FITNESS FOR A PARTICULAR PURPOSE ARE SPECIFICALLY EXCLUDED.

No one is authorized to make or modify any warranties on behalf of Sonance. The warranty stated above is the sole and exclusive remedy and Sonance's performance shall constitute full and final satisfaction of all obligations, liabilities and claims with respect to the Product.

IN ANY EVENT, SONANCE SHALL NOT BE LIABLE FOR CONSEQUENTIAL, INCIDENTAL, ECONOMIC, PROPERTY, BODILY INJURY, OR PERSONAL INJURY DAMAGES ARISING FROM THE PRODUCT, ANY BREACH OF THIS WARRANTY OR OTHERWISE.

This warranty statement gives you specific legal rights, and you may have other rights which vary from state to state. Some states do not allow the exclusion of implied warranties or limitations of remedies, so the above exclusions and limitations may not apply. If your state does not allow disclaimer of implied warranties, the duration of such implied warranties is limited to period of Sonance's express warranty.

Your Product Model and Description: **SLS HIGHOUTPUT LS87SAT** speaker.

Warranty Period for this Product: Five (5) years from the date on the original sales receipt or invoice or other satisfactory proof of purchase.

Additional Limitations and Exclusions from Warranty Coverage: The warranty described above is non-transferable, applies only to the initial installation of the Product, does not include installation of any repaired or replaced Product, does not include damage to allied or associated equipment which may result for any reason from use with this Product, and does not include labor or parts caused by accident, disaster, negligence, improper installation, misuse (e.g. overdriving the amplifier or speaker, excessive heat, cold or humidity), or from service or repair which has not been authorized by Sonance. Obtaining Authorized Service: To qualify for the warranty, you must contact your authorized Sonance Dealer/Installer or call Sonance Customer Service at (800) 582-0772 within the warranty period, must obtain a return merchandise number (RMA), and must deliver the Product to Sonance shipping prepaid during the warranty period, together with the original sales receipt, or invoice or other satisfactory proof of purchase.



©2013 Sonance. All rights reserved. Sonance is a registered trademarks of Dana Innovations. **Patent pending.**

Due to continuous product improvement, all features and specifications are subject to change without notice.

For the latest Sonance product specification information visit our website: www.sonance.com

SONANCE • 212 Avenida Fabricante • San Clemente, CA 92672-7531 USA

(800) 582-7777 or (949) 492-7777 • FAX: (949) 361-5151 • Technical Support: (800) 582-0772

www.sonance.com