

Sonance Architectural Series®

BPS-1 IN-CEILING SUBWOOFER INSTALLATION MANUAL



Introduction

Congratulations on your purchase of the Sonance Architectural Series BPS-1 Bandpass Subwoofer System. The BPS-1 system will add deep, powerful bass impact to any audio system that includes Sonance Architectural Series speakers. The BPS-1 cabinet remains completely hidden from view, delivering its bass energy through a Sonance Architectural Series Panel Bracket and Architectural Finish Component that is a discreet complement to the surrounding architectural space.

The complete BPS-1 Bandpass Subwoofer System is comprised of a BPS-1 bandpass subwoofer cabinet, a Bandpass Connector, a dedicated Sonamp® A150 power amplifier, an Architectural Series Panel Bracket and an Architectural Finish Component, all of which are available separately.

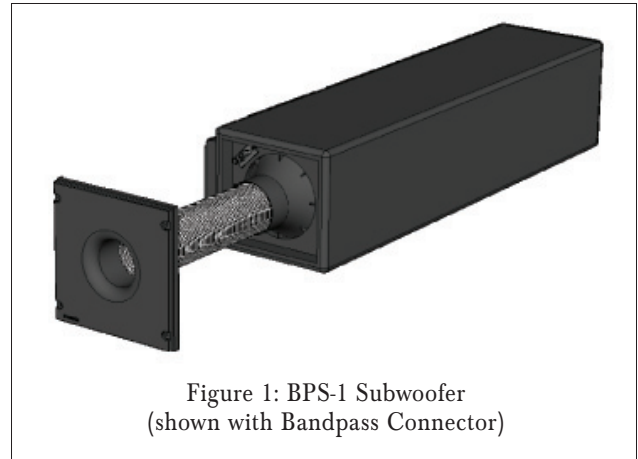

Figure 1: BPS-1 Subwoofer
(shown with Bandpass Connector)

Design and Features

- Delivers powerful, room-filling bass through a small grille that complements the room's architectural design.
- Trimless and truly flush-mount installation — the plane of the subwoofer grille is perfectly aligned with the plane of the ceiling.
- Available Bandpass Connectors allow the BPS-1 to be used with any size round or square Architectural Series Panel Bracket (even 4") to match other Architectural Series speakers in the audio system. Bandpass Connectors are heavily flared to minimize port noise during high-volume passages.
- The 8" woofer driver features a felted paper cone with a rubber surround and Kapton® voice coil former that provide years of reliable high-power operation. This allows the BPS-1 to be installed in a location that will have limited or no access.
- The very efficient 4th-order bandpass enclosure produces high output over the subwoofer's entire frequency range.
- The BPS-1 can be used with any separately available Architectural Series Finish Component: metal (with or without trim) or cloth (with or without trim).
- Sonamp A150 power amplifier (required, available separately) delivers 150 watts of power and provides flexible connections that integrate the BPS-1 system into any audio system. A built-in limiter prevents overdriving the BPS-1's woofer driver, even when using a single A150 to drive two BPS-1 subwoofer cabinets.
- Front-panel amplifier controls (volume, crossover frequency, phase) let you fine-tune the woofer's performance to match a variety of listening environments and personal preferences.

Box Contents

- (1) BPS-1 Subwoofer Cabinet (with vent tube attached)
- (8) 5/16" x 2" Lag Screws (for attachment to I-joists)
- (8) 5/16" x 3" Lag Screws (for attachment to standard joists)
- (2) Temporary Installation Brackets
- (1) Mounting Hole Drilling Template



Installing the BPS-1 Cabinet In New Construction

WARNING

DO NOT ATTACH THE BPS-1 TO AN I-JOIST THAT HAS NOT BEEN ADEQUATELY BRACED. DOING SO CAN CAUSE COLLAPSE, RESULTING IN INJURY OR DEATH. CONSULT WITH THE JOB'S GENERAL CONTRACTOR BEFORE ATTACHING THE BPS-1 TO AN I-JOIST.

1. Determine the location for the Architectural Series panel bracket/grille and install it according to its instruction manual.
2. Determine the location for the BPS-1 cabinet. The minimum required mounting area is 11" (279mm) W x 9 1/8" (232mm) H x 53 1/4" (1353mm) D.

IMPORTANT: THE CENTER OF PANEL BRACKET'S SPEAKER OPENING SHOULD BE APPROXIMATELY 12" FROM VENT TUBE END OF BPS-1 CABINET (SEE FIGURE 2). MAINTAINING THE VENT TUBE'S PROPER LENGTH IS INTEGRAL TO THE

BPS-1'S ACOUSTIC PERFORMANCE. LENGTHENING OR SHORTENING THE VENT TUBE TO FIT A DIFFERENT DISTANCE WILL ADVERSELY AFFECT THE BPS-1'S PERFORMANCE.

2. Attach the included Mounting Hole Drilling Template to the ceiling joist at the BPS-1 mounting location (see Figure 3). Make sure that the template is placed high enough so the BPS-1 cabinet will not contact the ceiling material after installation. (Contact can cause buzzing during operation.)
3. Drill eight 5/16" holes through the joist at the locations indicated on the Drilling Template (see Figure 3).
4. Screw the two Temporary Installation Brackets across the underside of the joist bay at the locations indicated on the Drilling Template (see Figure 4).

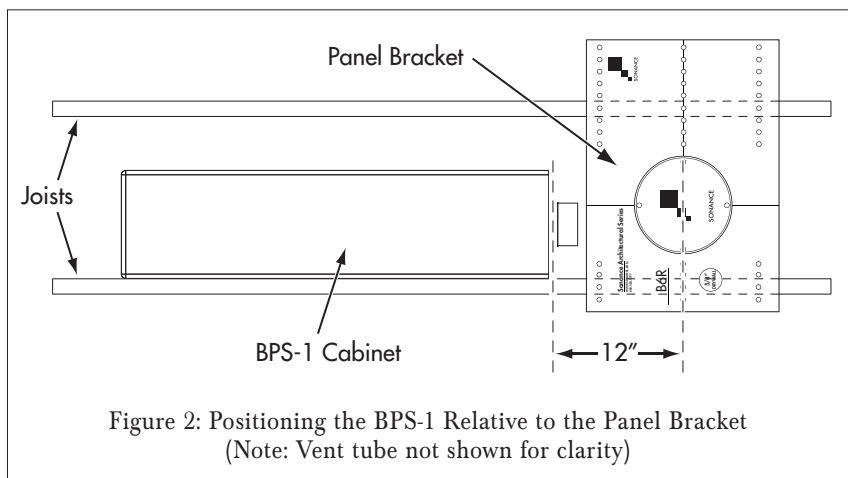

Figure 2: Positioning the BPS-1 Relative to the Panel Bracket
(Note: Vent tube not shown for clarity)

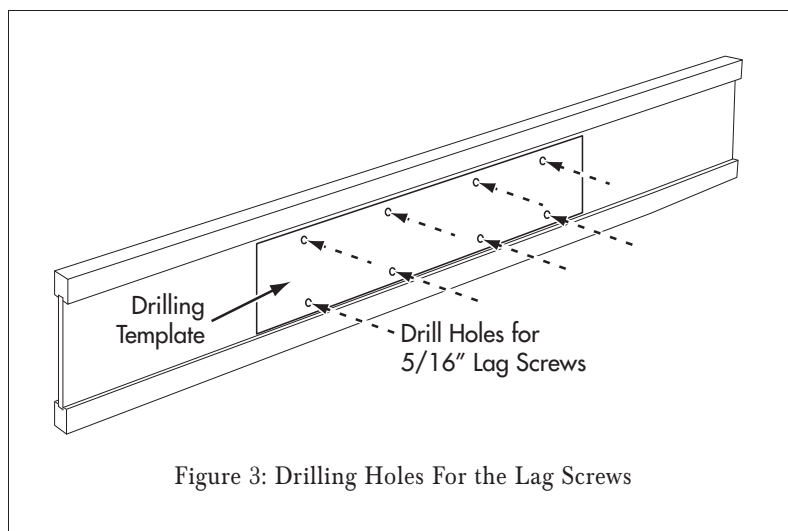

Figure 3: Drilling Holes For the Lag Screws

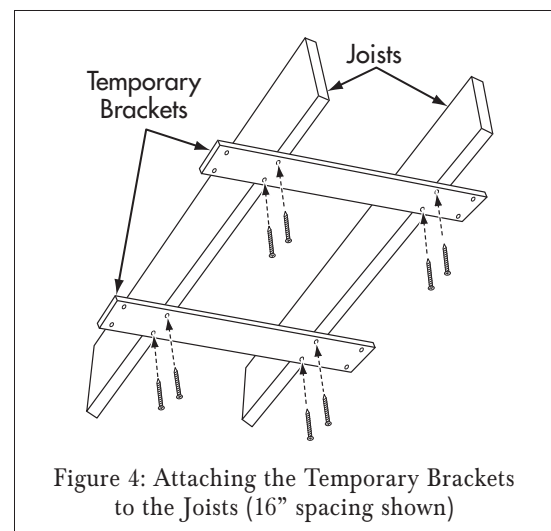

Figure 4: Attaching the Temporary Brackets to the Joists (16" spacing shown)

Sonance Architectural Series®

BPS-1 IN-CEILING SUBWOOFER INSTALLATION MANUAL



The Temporary Brackets have two sets of pre-drilled holes: One for 24" center-to-center joist spacing, and another for 16" center-to-center joist spacing.

NOTE: DO NOT USE NAILS TO ATTACH THE TEMPORARY BRACKETS — THEY WILL BE REMOVED AFTER THE BPS-1 CABINET IS ATTACHED TO THE JOIST.

5. Remove the Drilling Template from the joist.

6. Place the BPS-1 cabinet on the temporary brackets, aligning its mounting holes with the holes drilled through the joist. (Insert shims underneath the cabinet as necessary to bring its mounting holes in alignment with the holes drilled in the joist.)

7. Screw the eight included lag screws through the holes in the joist and into the holes in the side of the BPS-1 cabinet, as shown in Figure 5. Use the shorter lag screws for I-joist construction; use the longer lag screws for standard joist construction.

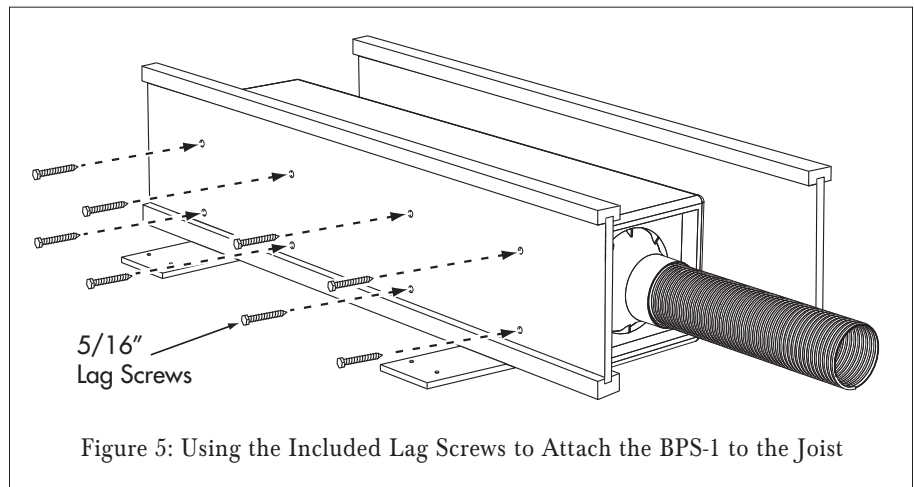

Figure 5: Using the Included Lag Screws to Attach the BPS-1 to the Joist

8. After confirming that the BPS-1 cabinet is securely attached to the joist, remove the temporary brackets from the underside of the joists.

Selecting the Proper Bandpass Connector

Sonance has BPS-1 Bandpass Connectors available that mate the BPS-1 to every size round and square Architectural Series panel bracket. The Bandpass Connectors provide proper acoustic performance while preventing port noise and buzzing during operation.

Select the Bandpass Connector that fits the particular size and shape Architectural Series Panel Bracket you installed. BPC8R/S fit 8" Panel Brackets, BPC6R/S fit 6" Panel Brackets, BPS4R/S fit 4" Panel Brackets (see Figure 6).

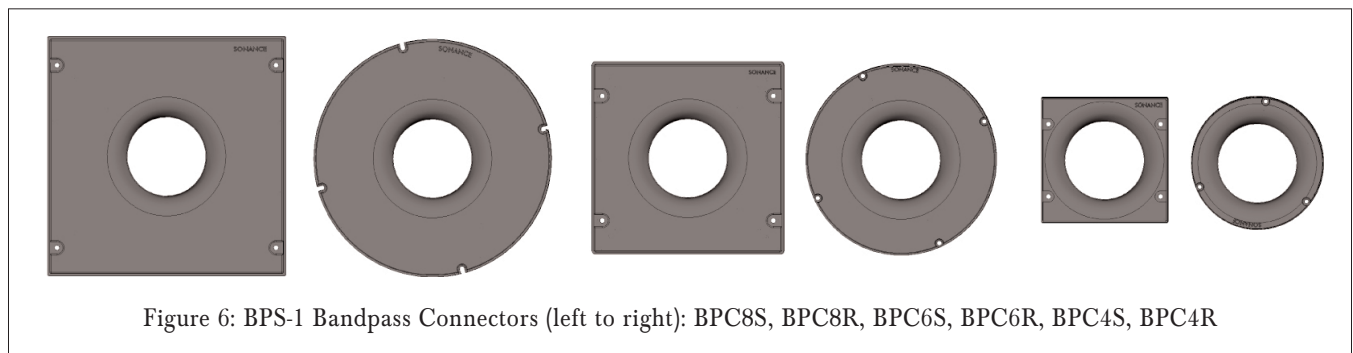

Figure 6: BPS-1 Bandpass Connectors (left to right): BPC8S, BPC8R, BPC6S, BPC6R, BPC4S, BPC4R

The Bandpass Connectors include hex screws, a hex wrench and Locktite.



Connecting the Vent Tube and Bandpass Connector

1. Use a Phillips screwdriver to remove the four screws that attach the paint shield to the Architectural Series Panel Bracket (see *Figure 7*).
2. Feed several inches of the Vent Tube through the Panel Bracket's speaker opening (see *Figure 8*).

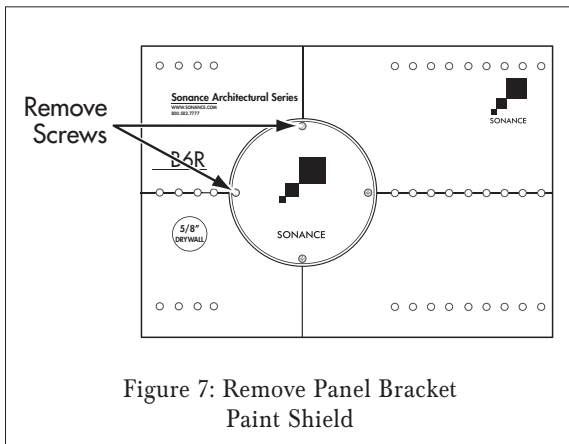

Figure 7: Remove Panel Bracket Paint Shield

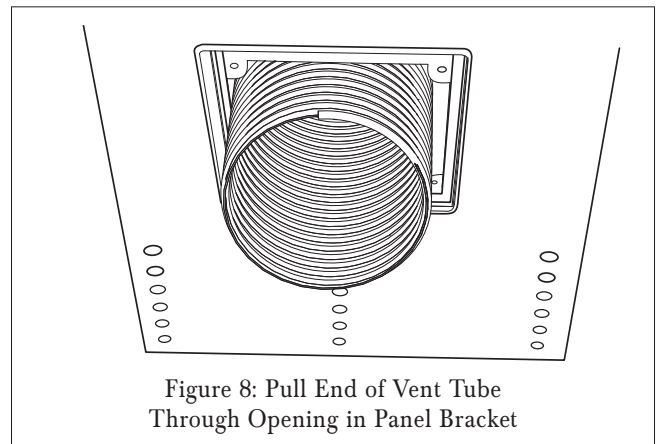

Figure 8: Pull End of Vent Tube Through Opening in Panel Bracket

3. Fit the Vent Tube Clamp (included with the Bandpass Connector) loosely around the vent tube (see *Figure 9*).

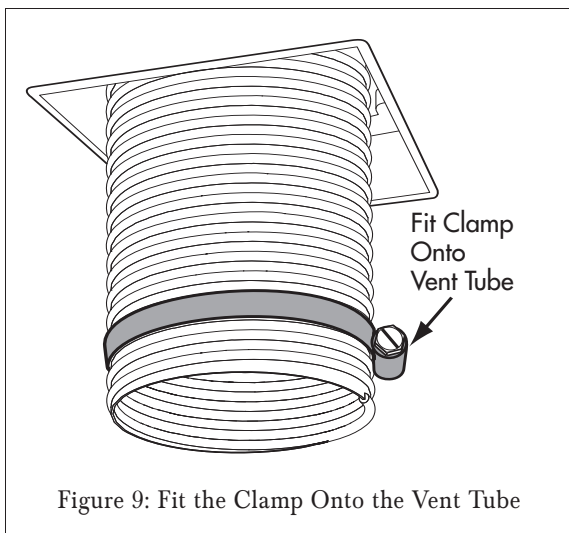

Figure 9: Fit the Clamp Onto the Vent Tube

4. Insert the Bandpass Connector's neck into the Vent Tube opening (see *Figure 10*).

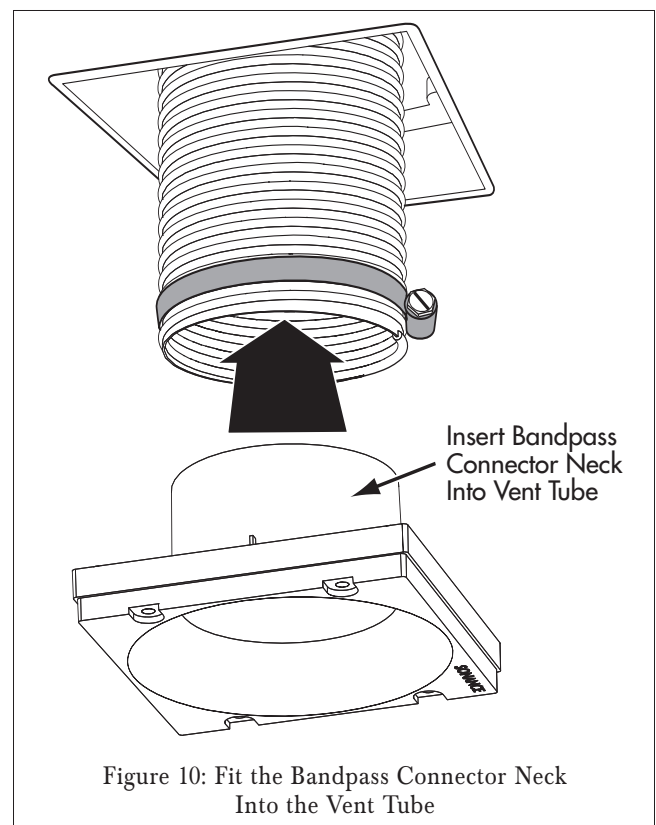

Figure 10: Fit the Bandpass Connector Neck Into the Vent Tube

Sonance Architectural Series®

BPS-1 IN-CEILING SUBWOOFER INSTALLATION MANUAL



5. Make sure the Vent Tube Clamp is positioned around the neck of the Bandpass Connector and tighten the clamp to secure the Vent Tube around the neck of the Bandpass Connector.
6. After confirming that the Vent Tube is securely fastened around the neck of the Bandpass Connector, push the Bandpass Connector into the Panel Bracket speaker opening.
7. Use the hardware included with the Bandpass Connector to attach it to the Panel Bracket (see Figure 11):
 - a) Apply a drop of Locktite to each hex screw.
 - b) Use the hex wrench included with the Bandpass Connector to hand-tighten the hex screws and secure the Bandpass Connector to the Panel Bracket.

NOTE: THE INCLUDED LOCKTITE IS REQUIRED TO PREVENT THE HEX SCREWS FROM COMING LOOSE DURING OPERATION

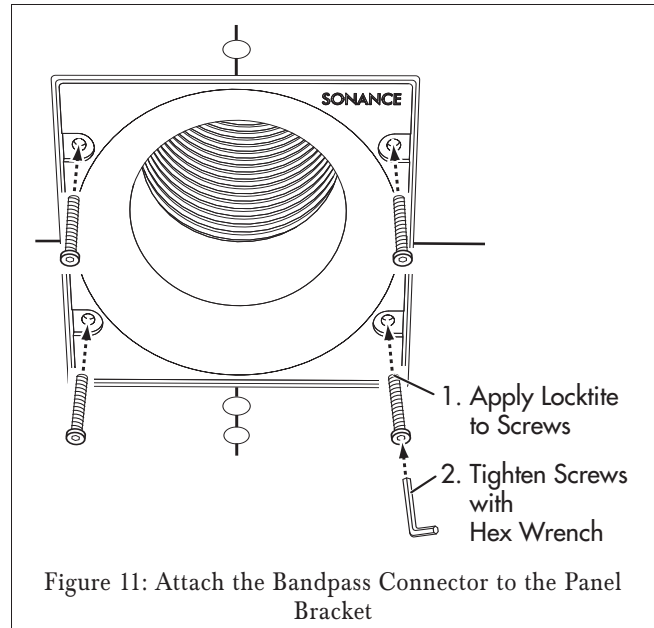

Figure 11: Attach the Bandpass Connector to the Panel Bracket

VERY IMPORTANT

USE ONLY THE SUPPLIED HAND-HELD HEX WRENCH TO ATTACH THE BANDPASS CONNECTOR.

DO NOT USE AN ELECTRIC SCREWDRIVER OR DRILL.

NEVER OVER-TIGHTEN THE BANDPASS CONNECTOR MOUNTING SCREWS. OVER-TIGHTENING THE SCREWS CAN FRACTURE THE BANDPASS CONNECTOR ASSEMBLY. THIS TYPE OF DAMAGE IS NOT COVERED BY THE ARCHITECTURAL SERIES WARRANTY.

Speaker Connections

IMPORTANT: THE BPS-1 IS SPECIFICALLY DESIGNED FOR USE WITH THE SONAMP A150 AMPLIFIER, WHICH HAS LIMITER CIRCUITRY THAT PREVENTS THE BPS-1'S WOOFER DRIVER FROM BEING DAMAGED BY AMPLIFIER CLIPPING. USE OF ANY OTHER POWER AMPLIFIER WITH THE BPS-1 COULD RESULT IN DAMAGE TO THE WOOFER AND WILL VOID THE BPS-1'S WARRANTY.

1. Run the speaker wire from the A150 amplifier to the BPS-1 cabinet.

NOTE: REFER TO THE A150 INSTRUCTION MANUAL FOR INFORMATION ABOUT AMPLIFIER CONNECTIONS.

2. Pass the speaker wire through the BPS-1's built-in wire tie, and route the wire's end to the speaker connector panel (see Figure 12).

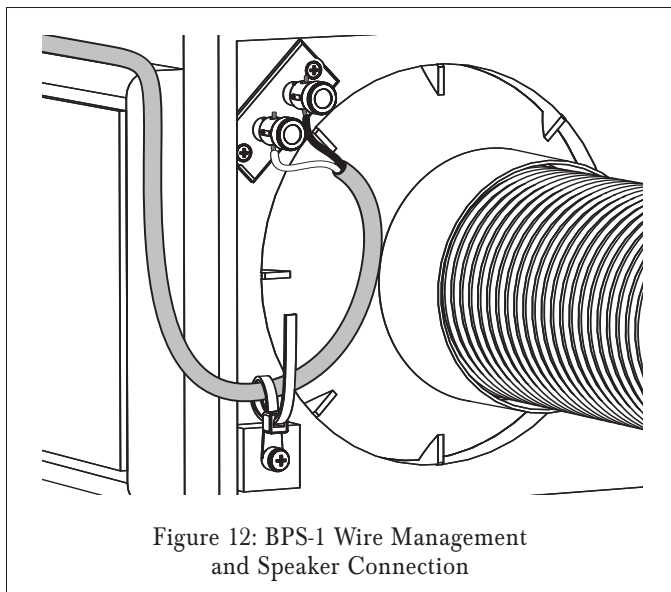

Figure 12: BPS-1 Wire Management and Speaker Connection

Sonance Architectural Series®

BPS-1 IN-CEILING SUBWOOFER INSTALLATION MANUAL



3. Strip $\frac{1}{4}$ " – $\frac{1}{2}$ " of insulation from each lead of the speaker wire. Twist the strands or tin the exposed wire with solder to ensure that there are no stray strands. (Stray strands that touch each other can cause a short-circuit that can damage the amplifier.)
4. The speaker's positive connector post is labeled with a red dot; the negative post is labeled with a black dot (see Figure 13). Push the top of each connector post down to open the connector and insert the exposed wires into the holes in the posts. Double-check that you connected amplifier "+" to speaker "+" and amplifier "-" to speaker "-".
5. Once you have verified that the connections are correct, tighten the wire tie to secure the speaker cable to the BPS-1 cabinet. This will help prevent the speaker from being accidentally disconnected in the future.

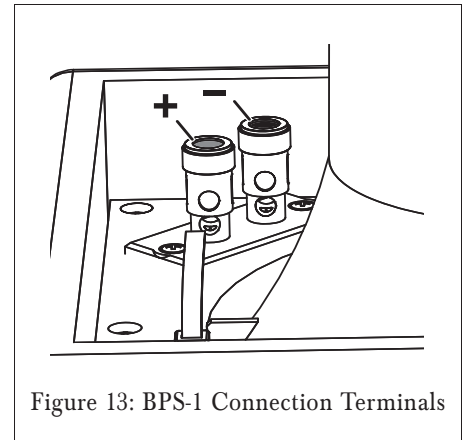

Figure 13: BPS-1 Connection Terminals

Installing the Architectural Finish Component

The Architectural Finish Component is installed after the ceiling is drywalled, finished and painted.

NOTE: FOR PAINTING INFORMATION, REFER TO THE INSTRUCTION MANUAL INCLUDED WITH THE ARCHITECTURAL FINISH COMPONENT.

1. The foam-tape covered rim on the back of the Finish Component inserts into the groove around the outer edge of the Bandpass Connector. See Figure 14.
2. Insert about half of the Architectural Finish Component rim into the groove on the Bandpass Connector. Gently fit the remaining half of the rim by working around the Baffle, fitting the rim into the groove as you go.

NOTE: FOR A PROPER INSTALLATION THE FOAM TAPE SHOULD FIT SECURELY AND CONSISTENTLY INTO THE GROOVE IN THE BAFFLE WITHOUT BINDING. IF NECESSARY, LIGHTLY LUBRICATE THE FOAM TAPE WITH WATER TO EASE INSERTION.

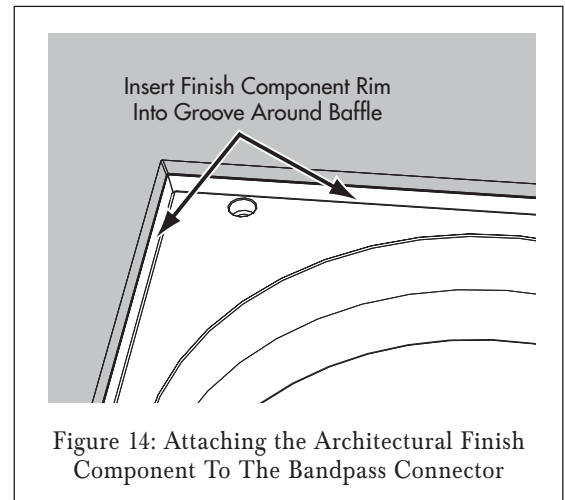

Figure 14: Attaching the Architectural Finish Component To The Bandpass Connector



Installing the Woofer Cabinet: Retrofit

The BPS-1 can be retrofit installed into a ceiling that has an attic or adequate crawlspace above it. Due to the variety of possible installation situations, it is not possible to recommend a single retrofit installation procedure. However, in any retrofit situation you should observe the following points to achieve a safe and noise-free installation:

- **Before installing the BPS-1 in any retrofit situation:** Review the section *Installing The BPS-1 Cabinet In New Construction* on pages 2 – 3 to become familiar with the installation procedure for new construction.
- Determine the location for the Architectural Series Panel Bracket and install it first (its location may be influenced by the locations of other AS speakers in the room). Then establish the location for the BPS-1 cabinet relative to the Panel Bracket. The vent end of the BPS-1 cabinet should be located 12" from the center of the Panel Bracket's speaker opening (see *Figure 2*, on page 2).
- When temporarily placing the BPS-1 cabinet in the ceiling bay before attaching it to the joist, take care to support it so that it does not break-through the ceiling material (The BPS-1 cabinet weighs 46 lbs.)
- Use the supplied drilling template to determine the locations of the mounting holes on the joist.
NOTE: MAKE SURE THE HOLES ARE HIGH ENOUGH ON THE JOIST SO THAT THE WOOFER CABINET WILL NOT CONTACT THE CEILING MATERIAL. (CONTACT WITH THE CEILING MATERIAL CAN CAUSE BUZZING DURING OPERATION.) THE ONLY CONTACT SHOULD BE BETWEEN THE CABINET'S GASKETED MOUNTING SURFACE AND THE MOUNTING JOIST.
- Once the BPS-1 cabinet is attached to the joist, complete the installation by following the instructions in the *Selecting The Proper Bandpass Connector, Connecting The Vent Tube And Bandpass Connector, Speaker Connections* and *Installing The Architectural Finish Component* sections on pages 3 – 6.

Specifications

Woofer:	8" (203mm) Long-throw felted paper cone with a rubber surround and a Kapton® voice coil former
Frequency Response:	35Hz – 150Hz ±3dB
Cabinet Dimensions (W x H x D):	11" x 9" x 39¼" (279mm x 229mm x 997mm)
Vent Tube Length:	15" (381mm)
Minimum Mounting Area Dimensions: (W x H x D)	11" x 9⅛" x 53¼" (279mm x 232mm x 1353mm)
Shipping Weight:	46 lbs (20.9kg) each

LIMITED FIFTEEN (15) YEAR WARRANTY

Sonance warrants to the first end-user purchaser that this Sonance-brand product ("Product"), when purchased from an authorized Sonance Dealer/Distributor and installed by a certified Sonance installer, will be free from defective workmanship and materials in the initial installation for the period stated below. Subject to the additional limitations stated below, Sonance will (a) at its option and expense during the warranty period, either repair the defect or replace the Product with a new or remanufactured Product or a reasonable equivalent, and (b) arrange at its reasonable expense to re-install the Product and prepare the surface of the speaker and/or mounting platform for finishing and nothing more.

EXCLUSIONS

TO THE EXTENT PERMITTED BY LAW, THE WARRANTY SET FORTH ABOVE IS IN LIEU OF, AND EXCLUSIVE OF, ALL OTHER WARRANTIES, EXPRESS OR IMPLIED, AND IS THE SOLE AND EXCLUSIVE WARRANTY PROVIDED BY SONANCE. ALL OTHER EXPRESS AND IMPLIED WARRANTIES, INCLUDING THE IMPLIED WARRANTY OF MERCHANTABILITY, IMPLIED WARRANTY OF FITNESS FOR USE, AND IMPLIED WARRANTY OF FITNESS FOR A PARTICULAR PURPOSE ARE SPECIFICALLY EXCLUDED. No one is authorized to make or modify any warranties on behalf of Sonance.

The warranty stated above is the sole and exclusive remedy and Sonance's performance shall constitute full and final satisfaction of all obligations, liabilities and claims with respect to the Product. IN ANY EVENT, SONANCE SHALL NOT BE LIABLE FOR CONSEQUENTIAL, INCIDENTAL, ECONOMIC, PROPERTY, BODILY INJURY, OR PERSONAL INJURY DAMAGES ARISING FROM THE PRODUCT, ANY BREACH OF THIS WARRANTY OR OTHERWISE.

This warranty statement gives you specific legal rights, and you may have other rights which vary from state to state. Some states do not allow the exclusion of implied warranties or limitations of remedies, so the above exclusions and limitations may not apply. If your state does not allow disclaimer of implied warranties, the duration of such implied warranties is limited to the period of Sonance's express warranty.

Your Product Model and Description: Architectural Series BPS-1 Bandpass Subwoofer

Warranty Period for this Product: Fifteen (15) years from the date on the original sales receipt, invoice or other satisfactory proof of purchase.

Additional Limitations and Exclusions From Warranty Coverage: The warranty described above is non-transferrable, applies only to the initial installation of the Product, does not include re-finishing of the speaker and/or mounting platform or surrounding surface, does not include damage to allied or associated equipment which may result for any reason from use with this Product, and does not include Product failure caused by accident, disaster, negligence, improper installation, misuse (e.g. overdriving the amplifier or speaker, excessive heat or cold or humidity, outdoor installation), or from service or repair which has not been authorized by Sonance.

Obtaining Authorized Service: To qualify for the warranty, you (1) must contact your authorized Sonance Dealer/Installer or call Sonance Customer Service at (800) 582-0772 within the warranty period, (2) must obtain a return merchandise number (RMA), and (3) deliver the Product to Sonance shipping prepaid during the warranty period, together with the original sales receipt, invoice or other satisfactory proof of purchase.



©2008 Sonance. All rights reserved.

Sonance and Architectural Series are trademarks or registered trademarks of Dana Innovations.

Due to continuous product improvement, all specifications are subject to change without notice.

For the latest Sonance product specification information visit our website: www.sonance.com

SONANCE • 212 Avenida Fabricante • San Clemente, CA 92672-7531 • USA
800-582-7777 or 949-492-7777 • FAX: 949-361.5151 • Technical Support: 800-582-0772

www.sonance.com