



INTRODUCTION

Thank you for purchasing Sonance Cinema Ultra II speakers. When properly installed, this product will provide you with years of entertainment pleasure.

To obtain the full potential of this product, please read all instructions before starting the installation.

PARTS LIST - Ultra II LCR

Each Sonance Cinema ULTRA II LCR speaker package includes the following items:

- (1) THX ULTRA II LCR in-wall speaker
- (1) Paintable grille
- (1) Plastic paint plug to protect speaker during painting
- (1) Mounting cutout template (in packaging)
- (6) Rotolock towers (4 corner and 2 side)

PARTS LIST - Ultra II SUR

Each Sonance Cinema ULTRA II SUR speaker package includes the following items:

- (2) THX ULTRA II SUR in-wall speakers
- (2) Paintable grilles
- (2) Plastic paint plug to protect speaker during painting
- (1) Mounting cutout template (in packaging)
- (12) Rotolock towers (8 corner and 4 side)

OPTIONAL ACCESSORIES

Cinema FlexBracket - part number 92023
 Plastic template to reserve hole in new construction.
 Designed to be used with the Rotolock3 mounting system.

DIMENSIONS - LCR

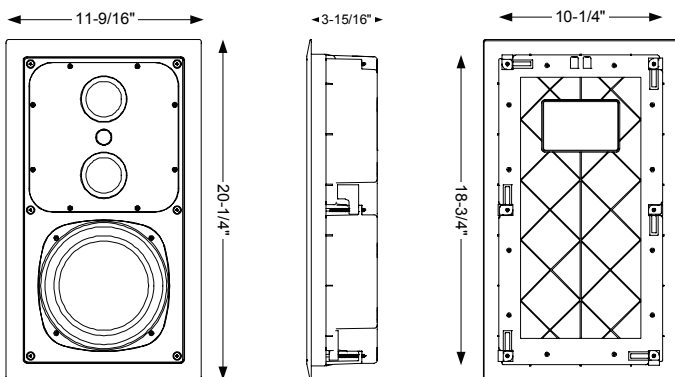

INSTALLATION INSTRUCTIONS

THX-ULTRA II IN-WALL SPEAKERS

PN. 33-3187 06/07

LEFT AND RIGHT SPEAKER PLACEMENT

The ideal mounting height for the LCR speakers is 38 to 42 inches from the floor to the center of the speaker baffle . This height corresponds to the height of your ear when you are sitting on a couch or in a chair.

Use the chart below to determine the placement height of the speakers. As part of the THX Ultra II approval process the LCR speakers have very broad vertical dispersion, approximately +/-10 degrees.

The left and right speakers should be separated from 6 to 10 feet apart center to center. If the speakers are separated too far apart the sound will seem to come from each front speaker. If the speakers are placed too close together the sound will seem too congested around the television.

Note: The Ultra II LCR can be placed horizontally. When placing the speaker horizontal the midrange / tweeter plate should be rotated 90 degrees to maintain proper dispersion.

CENTER CHANNEL SPEAKER PLACEMENT

If possible, locate the center channel in you home theater system the same height as your left and right speakers (38 to 42 inches from the floor). If you must place the speaker above or below a television, we recommend placing the speaker no more than 2 feet above or below the center of the left and right speakers.

Note: The Sonance Cinema Ultra II LCR speakers are magnetically shielded to eliminate interference with TV's, or other electrical devices.

OPTIMAL LCR PLACEMENT HEIGHT

Distance from Speaker	Minimum Height	Maximum Height
6 feet	27"	53"
8 feet	23"	57"
10 feet	19"	61"
12 feet	15"	65"
14 feet	11"	69"

Height measured to center of speaker from floor

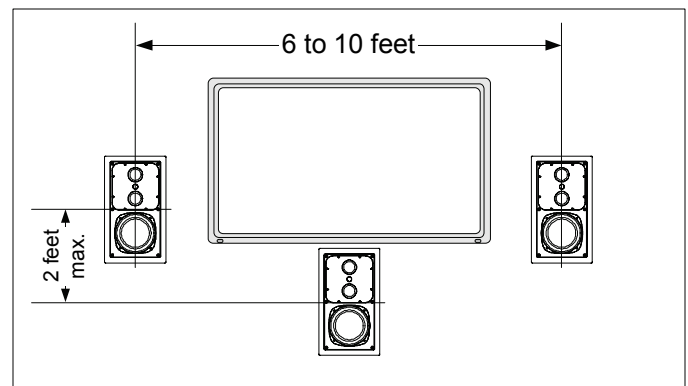



The Leader in Architectural Audio™

SURROUND SPEAKER PLACEMENT

The ideal mounting height for the Cinema Ultra II SUR speakers is 24 to 36 inches above the height of your ear when you are seated. This would place the speaker from 60" - 80" from the floor to the center of the speaker baffle .

The Cinema Ultra II SUR speakers should be placed directly to the left and right of the listening area, as shown below.

Another option is to mount the surround speakers in the ceiling. When the speakers are installed in the ceiling the speakers should be placed to the left and right sides of the listening position and separated 8 to 10 feet apart.

Note: The Cinema Ultra II SUR can be placed horizontally. When placing the speaker horizontal the midrange / tweeter plate should be rotated 90 degrees to maintain proper coverage.

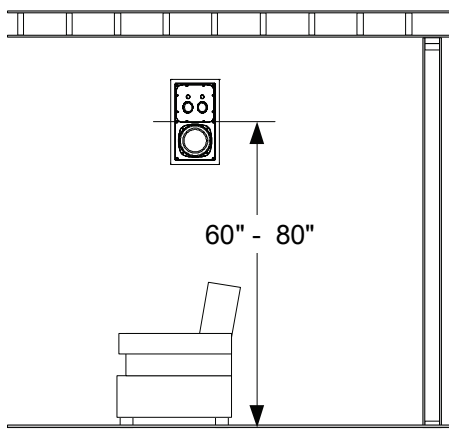

SURROUND BACK SPEAKER PLACEMENT

The back speakers in a 6.1 or 7.1 system should be installed on the rear wall of the listening room at the same height as the left and right surround speaker.

If your system will primarily be used for multi-channel music we recommend the use of one or two additional LCR speakers for the back surround channel. If you will be playing mostly movies the use of one or two additional Cinema Ultra II SUR speakers is recommended.

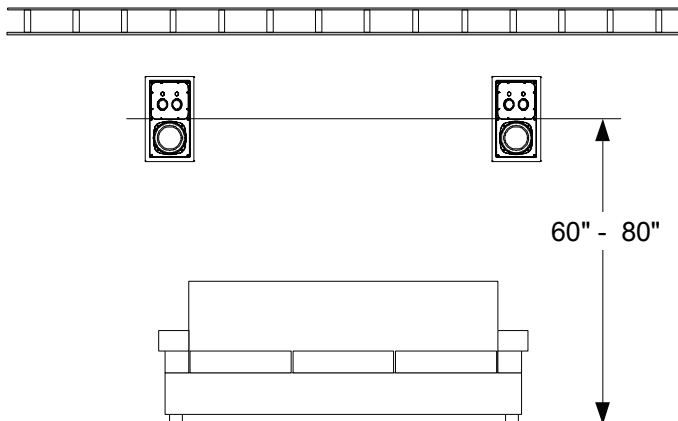

INSTALLATION INSTRUCTIONS

THX-ULTRA II IN-WALL SPEAKERS

DIMENSIONS - SUR

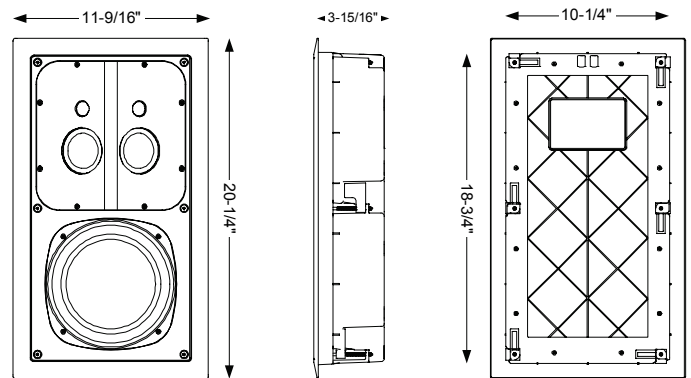

MOUNTING OPTIONS

New Construction

The Cinema Ultra II series speakers feature an integral Rotolock3 mounting system for quick mounting into walls. The Cinema Ultra II series FlexBracket is only necessary in new construction installations when reserving a location for the speaker is desired.

The FlexBracket will serve as a guide for the dry wall installer when cutting holes for in-wall speakers. The FlexBracket should be nailed or screwed to the studs so that the hole is in the desired location once the drywall is installed.

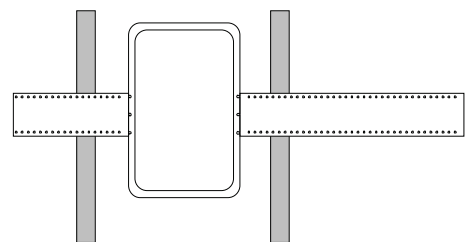

Cinema Ultra II series FlexBracket

Retrofit

With the Rotolock system, the speaker can be installed directly into existing walls. Once the hole is cut and the cable is run, the speakers can be installed in a matter of seconds.

Once you have determined the area you would like to locate your speakers, you will need to do an obstruction survey. Before you cut the hole for the speaker, be certain no studs, conduit, pipe, heating duct or air return will interfere with the speaker.

The cutout for the Cinema Ultra II series is 10-1/4 (260mm) x 18-3/4" (476mm). There must also be 3-15/16" of depth within the wall for the speaker.

A cut out template is provided in the packaging of the speaker. Position the template where the speaker is to be located and pencil an outline on the wall. If you are unsure about obstructions, drill a small hole in the center of the cutout and insert a coat hanger into the hole to feel for possible obstructions. If no obstructions are found, proceed with cutting the hole using a drywall saw and run the speaker wires.

LCR AND SUR - INSTALLATION STEPS

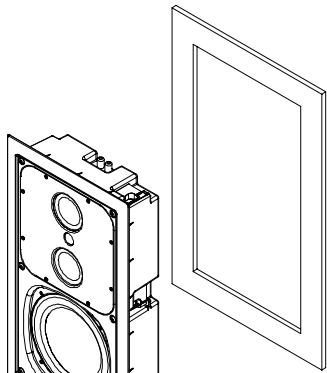

Step 1

Remove the paint plug from the speaker. Attach the wire from your amplifier to the binding posts terminals on the back of the speaker. Double check the polarity of the speaker wires, amplifier + to speaker + and amplifier - to speaker -. Proper polarity is critical in home theater installations.

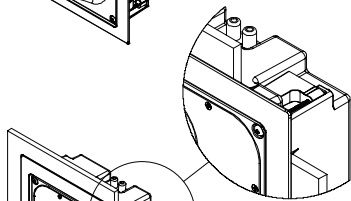

Step 2

Make sure the Roto-Lock clamps are tucked within the recessed area of the back box, and within the cutout border. Insert the speaker into the hole in the wall.

Note: The maximum clamp thickness is 1-1/4" (32mm). The minimum clamping thickness is 1/8" (3.2mm)

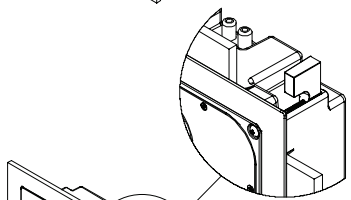

Step 3

Tighten the six screws on the front of the baffle. The Roto-Lock clamps will rotate into position automatically and begin clamping. When you notice resistance on the six screws, the speaker has been clamped successfully. Do not over tighten the screws.

Note: The flange is designed to flex and conform to any small imperfections in the wall surface. The screws should not be tightened so far that the flange bows out.

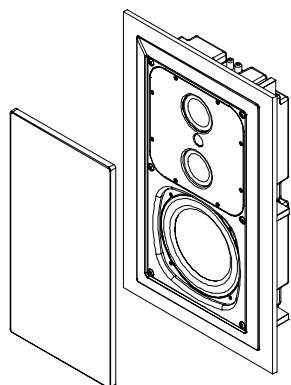

Step 4

After the speaker is mounted, the grille can be installed. Insert about half of the grille into the groove at the edge of the speaker. Gently fit the remaining half of the grill into the speaker.

Note: The torque applied to the mounting screws can be adjusted for proper grille fit.

Step 5

The final and most important step in the installation is to calibrate your system. Follow your surround processor instructions for proper calibration procedures.

BACK BOX REMOVAL

In some installations the wall depth may not accommodate the integrated back box. The following steps will allow you to install the speaker into a non-standard wall.

The following steps should also be followed if you are installing the Cinema Ultra II LCR or SUR speakers into old Cinema 1 or 2 brackets or acoustic enclosures.

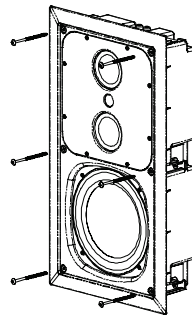

Step 1

Remove the six Rotolock screws from the speaker. Keep these screws, you will use them for the Rotolock feet.

Step 2

Remove the six Rotolock clamps. Keep the Rotolock clamps, you will use these after the towers are installed.

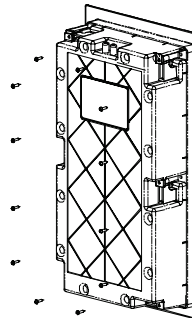

Step 3

Remove the twelve screws that hold the back box to the frame. Keep the twelve screws, you will use them to attach the towers.

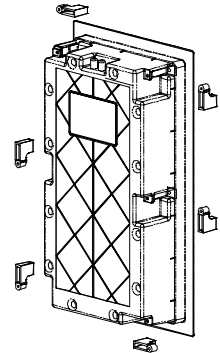

Step 4

Remove the back box. The wires that connect the crossover to the binding posts will need to be removed at this point.

Note: If you are installing the speaker into an old Cinema series acoustic enclosure or fixed depth bracket, the speaker is ready to install at this point. Use the six Rotolock screws to attach the speaker to the acoustic enclosure or fixed depth bracket.

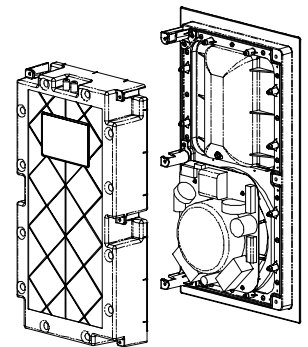

Step 5

Using the twelve screws you removed from the back box you can now attach the six Rotolock towers. Use two screws in each tower.

Note: Included with each speaker are 4 corner towers and 2 side towers.

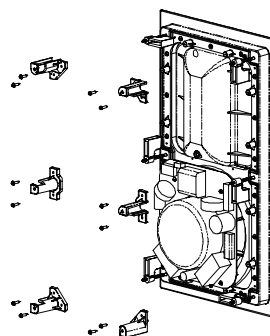

Step 6

Install the six Rotolock screws into the toggle clamps. The speaker is now ready to install.

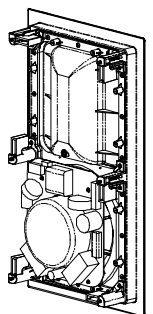

WIRE GAUGE AND QUALITY

The total wire resistance should be less than 10% of the speaker impedance. If using an 4 ohm speaker, your total wire resistance should be no more than 0.4 ohms.

In simple terms, the extra resistance from the wire will have a very negative effect on the sound quality of the speaker. The sound can be less dynamic, definition of bass frequencies can be reduced, and in extreme cases, the high frequencies can be attenuated. Amplifier power is also wasted in the wire, reducing the maximum output level of the system.

Please refer to the following chart when deciding on the appropriate wire gauge for your installation.

Wire resistance in Ohms vs. length of cable run						
Distance in Feet	50'	100'	150'	200'	250'	300'
20 gauge	1.04	2.07	3.11	4.14	5.18	6.22
18 gauge	.65	1.30	1.96	2.61	3.26	3.91
16 gauge	.41	.82	1.22	1.63	2.04	2.45
14 gauge	.26	.52	.77	1.03	1.29	1.55
12 gauge	.16	.32	.49	.65	.81	.97
10 gauge	.10	.20	.31	.41	.51	.61

PAINTING THE SPEAKERS AND GRILLES

Speakers and grilles can be painted before installation, which will eliminate the "paint scar" if the speaker needs to be removed for service. Speakers may also be painted after installation, but before the grilles are attached. All speakers come from the factory fitted with a plastic "paint plug." Use the paint plug to protect the drivers while the flange is being painted with the wall.

Sonance suggests always painting the grilles separate from the speaker. The grilles may be lightly sprayed with thin paint (5 parts thinning agent to 1 part paint), but be careful not to plug the holes. Too much paint will adversely affect the sound of the speaker.

Once the grilles and flange are painted and dry, remove the paint plug from the flange and install the grilles.

SPECIFICATIONS

Cinema Ultra II - LCR

Tweeter	3/4" (19mm) Silk dome, shielded magnet
Midrange	Two - 3.0" (76mm) One piece black Aluminum cones with rubber surrounds, shielded magnets
Woofer	8" (203mm) One piece black Aluminum cone with a rubber surround, shielded magnet
Frequency Response	70Hz - 20kHz +/- 3dB
Impedance	6 ohms nominal - 4 ohms minimum
Power Handling	5 - 200 Watts
SPL	90 dB
Grille	Aluminum
Adjustments	Rotating Midrange / tweeter array
Dimensions H x W x D	20-1/4" (514mm) x 11-9/16" (294mm) x 3-15/16" (100mm)
Cutout Dim H x W	18-3/4" (476mm) x 10-1/4 (260mm)
Shipping Weight	18 lbs (8.2 KG) each

Cinema Ultra II - SUR

Tweeter	Two - 3/4" (19mm) Silk domes
Midrange	Two - 3.0" (76mm) One piece black Aluminum cones with a rubber surround
Woofer	8" (203mm) One piece black Aluminum cone with a rubber surround
Frequency Response	40Hz - 20kHz +/- 3dB
Impedance	6 ohms nominal - 4 ohms minimum
Power Handling	5 - 200 Watts
SPL	90 dB
Grille	Aluminum
Adjustments	Rotating Midrange / tweeter array
Dimensions H x W x D	20-1/4" (514mm) x 11-9/16" (294mm) x 3-15/16" (100mm)
Cutout Dim H x W	18-3/4" (476mm) x 10-1/4 (260mm)
Shipping Weight	29 lbs (13.2 KG) per pair

INSTALLATION INSTRUCTIONS

THX - ULTRA II IN - WALL SPEAKERS

TECHNICAL ASSISTANCE AND SERVICE

The Technical Assistance Department at Sonance is available at (800) 582-0772 or (949) 492-7777 to answer any questions concerning the operation and installation of your speakers between the hours of 7:00 AM and 5:00 PM Pacific time, Monday through Friday, except holidays.

In the event your unit should need repair or service, you may return the unit to your authorized dealer or use the following guidelines:

1. Be prepared to state the model number and / or serial number, date of purchase and dealer's name and address when calling.
2. Contact Sonance directly at (800) 582-0772 or (949) 492-7777 or at www.sonance.com
3. If you are returning the product directly to Sonance, call us to obtain a return authorization number before shipping. YOU MUST HAVE PRIOR AUTHORIZATION TO RETURN YOUR UNIT.
4. The original packaging must be used. If the original packaging is unavailable, replacements can be obtained from Sonance for a small fee.
5. Ship the product via a package delivery service such as UPS or Federal Express. Please do not use the U.S. Postal Service.
6. Write the return authorization number on the outside of the box.
7. Ship to:
Attn: Quality Assurance Department
Sonance
212 Avenida Fabricante
San Clemente, CA 92672-7531
8. FREIGHT COLLECT SHIPMENTS WILL BE REFUSED !

Limited Lifetime Warranty

Sonance warrants to the original retail purchaser only that this Sonance product will be free from defects in materials and workmanship, provided the speaker was purchased from a Sonance Authorized Dealer after September 1, 2003. Purchases made before that date carry a limited 5 year warranty.

Defective products must be shipped, together with proof of purchase, prepaid insured to the Sonance Authorized Dealer from whom they were purchased, or to the Sonance factory at the address listed on this installation instruction manual. Freight collect shipments will be refused. It is preferable to ship this product in the original shipping container to lessen the chance of transit damage. In any case, the risk or loss or damage in transit is to be borne by the purchaser. If, upon examination at the Factory or Sonance Authorized Dealer, it is determined that the unit was defective in materials or workmanship at any time during this warranty period, Sonance or the Sonance Authorized Dealer will, at its option, repair or replace this product at no additional charge, except as set forth below. If this model is no longer available and can not be repaired effectively, Sonance, at its sole option may replace the unit with a current model of equal or greater value. In some cases where a new model is substituted, a modification to the mounting surface may be required. If mounting surface modification is required, Sonance assumes no responsibility or liability for such modification. All replaced parts and product become the property of Sonance. Products replaced or repaired under this warranty will be returned to the original retail purchaser, within a reasonable time, freight prepaid.

This Warranty does not include service or parts to repair damage caused by accident, disaster, misuse, abuse, negligence, inadequate packing or shipping procedures, commercial use, voltage inputs in excess of the rated maximum of the unit, or service, repair or modification of the product which has not been authorized or approved by Sonance. This Warranty also excludes normal cosmetic deterioration caused by environmental conditions. This Warranty will be void if the Serial Number on the product has been removed, tampered with or defaced. This Warranty is in lieu of all other expressed warranties. If the product is defective in materials or workmanship as warranted above, the purchaser's sole remedy shall be repair or replacement as provided above. In no event will Sonance be liable for any incidental or consequential damages arising out of the use or inability to use the product, even if Sonance or a Sonance Authorized Dealer has been advised of the possibility of such damages, or for any claim by any other party.

Some states do not allow the exclusion or limitation of consequential damages, so the above limitation and exclusion may not apply. All implied warranties on the product are limited to the duration of this expressed Warranty. Some states do not allow limitation on the length of an implied warranty. If the original retail purchaser resides in such a state, this limitation does not apply.

w w w . s o n a n c e . c o m