

INSTALLATION MANUAL

SONANCE ORIGINAL SERIES MEDIUM ROUND SPEAKERS



Introduction

Thank you for purchasing Sonance Original Series Medium Round speakers. When properly installed, these speakers will give you many years of entertainment pleasure. To get the most out of your new speakers, please read this manual thoroughly before you begin installation.

Since all of the Original Series Medium speakers have exactly the same footprint and have identical installation requirements, the directions in this manual apply to each of the following models: 625R, 624R, 623R, 622R, 621R, 623R TL, 622R TL, and 621R TL.

To achieve the best performance, Sonance recommends that these speakers be installed by a Sonance Authorized Dealer/Installer.

SAFETY WARNING:

THESE SPEAKERS HAVE FASTMOUNT® TABS THAT PREVENT THE SPEAKER FROM FALLING OUT OF THE MOUNTING HOLE DURING THE INSTALLATION PROCESS.

THE EDGES OF THE FASTMOUNT TABS ARE VERY SHARP. USE CAUTION WHEN HANDLING THE SPEAKER.

SEE FIGURE 4 FOR COMPLETE INFORMATION ABOUT THE FASTMOUNT TABS.

Parts List

Your Original Series Medium Round speakers include the following:

- (2) Original Series Medium Round Speakers
- (2) Paintable grilles
- (2) Plastic paint plugs to protect speakers during painting
- (1) Mounting cutout template (in packaging)

Speaker Placement

The locations of the speakers should be determined by considering the primary listening location, the primary use for the speakers (distributed audio, 2-channel, or home theater), and aesthetic values. For optimum results, contact your Authorized Sonance Dealer for advice.

Distributed Audio Placement

Sonance Original Series Medium Round speakers have very smooth and predictable off-axis response, increasing placement options while providing excellent coverage in distributed audio systems from a wide variety of installation locations.

The following chart shows how far apart the speakers can be placed at different ceiling heights while still providing good coverage. The distances are based on ear heights of 62" (1.5 m) for standing listeners and 40" (1 m) for seated listeners.

Speaker Spacing for a Distributed Audio System		
	Standing Listener	Seated Listener
8-foot ceiling	5.7 ft (1.7 m) apart	9.5 ft (2.9 m) apart
10-foot ceiling	9.7 ft (3.0 m) apart	13.5 ft (4.1 m) apart
12-foot ceiling	13.7 ft (4.2 m) apart	17.5 ft (5.3 m) apart
14-foot ceiling	17.7 ft (5.4 m) apart	21.5 ft (6.6 m) apart

Home Theater Speaker Placement

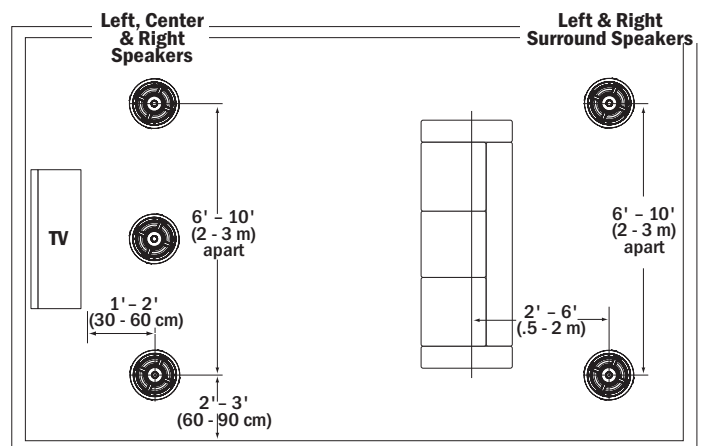

Figure 1: 5.1-channel home theater placement

Left, Center & Right Channels

- Place the left, center and right speakers from 1-2 feet (30-60 cm) in front of the video screen, anywhere from 6 feet to 10 feet (2-3 m) apart, with the center channel speaker as close to midway between the left and right speakers as possible.
- Place the left & right speakers at least 2 to 3 feet (60-90 cm) away from the side walls.
- The main listening position should be between 4 and 10 feet (1.2-3 m) away from the speakers.
- If necessary, pivot the tweeter and the woofer of each speaker towards the listening position to maximize the soundstage. The pivoting feature is available only on the Original Series Medium Round 625R, 624R, 623R, 622R, and 621R speakers. The adjustable three-position tweeter switch is available on the 625R, 624R, 623R, and 623R TL.

Use Figure 1 as a guide.

Left & Right Surround Speakers (5.1-Channel System)

Locate the left and right surround speakers on the ceiling between 2 and 6 feet (.6 - 2 m) behind the listening position. The speakers should be between 6 and 10 feet (2 - 3 m) apart. Since the surround speakers are usually called-upon to create diffuse effects like the sound of wind or rain, they can be located close to walls without adversely affecting sound quality.

- You can create a more diffuse, spacious surround effect by pivoting the tweeter and the woofer towards a wall or window, away from the listeners. This feature is available only on the 625R, 624R, 623R, 622R, and the 621R speakers.

Use Figure 1 as a guide.

Left & Right Surround and Surround Back Speakers (7.1-Channel System)

- Left & Right Surround Speakers: Place the left and right surround speakers directly to the sides of the listening position, between 6 feet and 10 feet (2 - 3 m) apart. The speakers can be placed close to the side walls.
- Surround Back Speakers: Place the surround back speakers between 2 and 6 feet (.6 - 2 m) behind the listening position. The surround back speakers should be closer together than the left and right surround speakers -- between 3 and 6 feet (1 - 2 m) apart. Like the left and right surround speakers, the surround back speakers can be located close to walls without adversely affecting sound quality.
- You can create a more diffuse, spacious surround effect by pivoting the tweeter and the woofer towards a wall or window, away from the listeners. This feature is available only on the Original Series Medium Round 625R, 624R, 623R, 622R, and 621R speakers. The adjustable three-position tweeter switch is available on the 625R, 624R, 623R, and 623R TL.

Use Figure 2 as a guide.

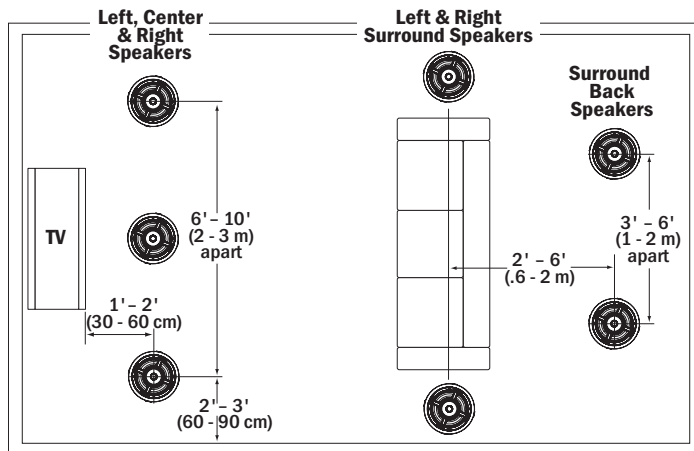

Figure 2: Left, Center, & Right Home Theater Speaker Placement

Wire Gauge

Extra resistance in the speaker wire can make speakers sound less dynamic and reduce definition of the bass frequencies. In extreme cases, it can even attenuate high frequencies. Also, amplifier power is wasted in wire with extra resistance, reducing your system's maximum output level.

To prevent degrading sound quality, the total wire resistance should be less than 10% of the speaker's impedance. This means that for an 8-ohm speaker, the total resistance of the wire should be less than 0.8 ohms.

Refer to the table below to select the proper wire gauge for your system.

Wire Resistance in Ohms vs. Length of Cable Run						
Distance in Feet	50	100	150	200	250	300
Distance in Meters	15.2	30.5	45.7	61	76.2	91.5
20 gauge	1.04	2.07	3.11	4.14	5.18	6.22
18 gauge	.65	1.30	1.96	2.61	3.26	3.91
16 gauge	.41	.82	1.22	1.63	2.04	2.45
14 gauge	.26	.52	.77	1.03	1.29	1.55
12 gauge	.16	.32	.49	.65	.81	.97
10 gauge	.10	.20	.31	.41	.51	.61

Preparing the Installation Location

All Sonance speakers are designed to be relatively insensitive to variations in enclosure volume. To achieve the ultimate performance from your speakers, a section of the ceiling bay can be partitioned to form a back box. Building such an enclosure will create a dramatic improvement in your speakers' bass performance and power handling.

Ideal internal back box volume requirements:

0.62 ft³ (.0175 m³) overall size

Insulating the Ceiling Cavity

You can reduce sound transmission to adjacent rooms and further improve speaker performance by inserting a sheet of unfaced fiberglass insulation over the back of the speaker.

To reduce noise produced by unsupported drywall, install fiberglass insulation in the ceiling bays adjacent to the speaker location.

ORIGINAL SERIES MEDIUM ROUND SPEAKERS

Optional Retrofit Enclosures

For installations where it isn't possible to partition the ceiling bay to form a back box (such as when you're retrofitting the speakers into an existing ceiling), you can effectively reduce sound transmission into adjacent rooms by fitting the speakers with the optional Medium Round Retrofit Enclosure (part# 92343) or the Medium Round 6½" Wooden Enclosure (part# 91688). These enclosures are designed specifically to be used with these speakers, and will noticeably reduce sound "spillover" from the rears of the speakers into adjacent rooms and spaces.

Installing the Speakers

Before Installation: New Construction

For installations in new construction, Sonance recommends using a Flex Bracket (part# 92337) to reserve a location for the speaker. The Flex Bracket has perforated wings that can be positioned at any angle around the bracket, and is nailed or screwed to the studs. This serves as a guide for the drywall so that the speaker hole will be in the desired location once the drywall is installed.

Before Installation: Retrofit

1. Determine the location for the speaker (see Speaker Placement on page 1).
2. Perform an obstruction survey to be certain that there are no studs, conduit, pipes, heating ducts or air returns that will interfere with the speaker.
3. Mounting space requirements:
 - Medium Round speakers: 8¼" (210mm) diameter cut-out; 4¾" (121mm) depth within the mounting cavity.
 - Medium Round ThinLine® speakers: 8¼" (210mm) diameter cut-out; 3⅓" (77mm) depth within the mounting cavity.
4. Position the included cutout template where the speaker is to be located and pencil an outline on the ceiling.
 - If you are unsure about obstructions, drill a small hole in the center of the outline and insert a coat hanger wire into the hole to feel-around for possible obstructions.
5. Cut the mounting hole using a keyhole or drywall saw, and run the speaker wires from the mounting hole to the amplifier location.

NOTE: CONSULT LOCAL BUILDING CODES BEFORE RUNNING SPEAKER WIRES THROUGH CEILINGS.

Installation

Sonance Original Series Medium Round speakers feature exclusive FastMount tabs and an integral Roto-Lock® mounting system for quick mounting directly into existing ceilings and walls.

WARNING: THE EDGES OF THE FASTMOUNT TABS ARE VERY SHARP. USE CAUTION WHEN HANDLING THE SPEAKER.

1. Remove the paint plug from the speaker.
2. Run speaker wire from each speaker to the amplifier location.

3. Strip ¼" - ½" (6mm - 12mm) of insulation from each speaker lead. Twist the strands or tin the exposed wire with solder to ensure that there are no stray strands. (Stray strands that touch each other can cause a short circuit that can damage the amplifier.)
 4. The speaker's connector posts are spring-loaded. Push the top of each connector post down to open the connector and insert the exposed wires into the holes in the posts.
 - The speaker's positive post is labeled with a red dot; the negative post is labeled with a black dot. Connect the speaker wire to the terminals on the speaker. Double-check that you connected amplifier "+" to speaker "+" and amplifier "-" to speaker "-".
 5. Make sure all the Roto-Lock clamps are in the full clockwise position so that they are tucked within the mounting hole's border. Insert the speaker into the hole in the ceiling. The Roto-Lock system can accommodate a maximum ceiling material thickness of 1¼" (32mm).
 - The FastMount tabs will prevent the speaker from falling out of the mounting hole, allowing the installer to let go of the speaker to pick up tools or other items (see Figure 4).
- NOTE:** THE FASTMOUNT TABS ARE DESIGNED FOR ONE-TIME USE ONLY. IF THE SPEAKER IS REMOVED FROM THE MOUNTING HOLE, THE FASTMOUNT TABS WILL DISCONNECT AND REMAIN INSIDE THE WALLS.
6. Tighten the four screws on the front of the speaker baffle. The Roto-Lock clamps will automatically rotate into position and begin clamping the speaker (see Figure 4).
 - When you notice resistance on the screws the speaker has been clamped successfully.

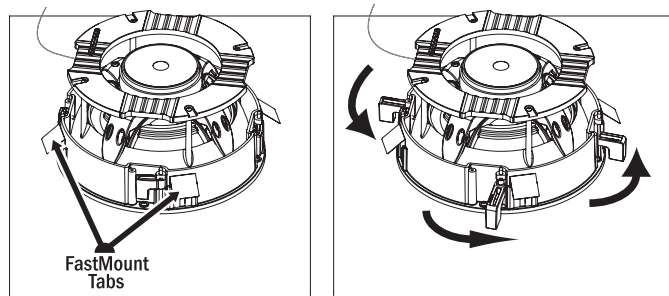

Figure 4: Original Series Medium Round Speaker Installation

IMPORTANT: ALWAYS USE LOW-TORQUE SETTINGS. NEVER OVERTIGHTEN.

NOTE: ADJUSTING THE TENSION OF THE ROTO-LOCK CLAMPS SO THAT THE SPEAKER FRAME IS FLAT WILL HELP ENSURE THAT THE GRILLE CONTACTS THE CEILING ALL THE WAY AROUND THE SPEAKER FOR A PROPER FIT.

7. Attach the grille after the speaker has been installed. Insert about half of the grille into the groove at the edge of the speaker. Gently fit the remaining half of the grille by working around the speaker, fitting the grille into the groove as you go.
 - You can adjust the torque to the Roto-Lock screws to achieve a proper grille fit.

Painting the Speakers and Grilles

All Sonance Original Series Medium speakers come from the factory fitted with a plastic "paint plug." Use the paint plug to protect the speaker drivers while the flange is being painted along with the wall. You can paint the speakers and grilles before installing them, which will eliminate the "paint scar" if the speaker ever needs to be removed for service. You can also paint the speakers after installation, but before the grilles are attached.

Sonance always suggests painting the grille separately from the speaker. Before painting, carefully remove the under-grille cloth. It is held in place with a light tacking glue that makes it easy to remove.

Spray the grilles with thinned paint (5 parts thinner to 1 part paint), being careful not to plug the holes. Too heavy a coat of paint on the grille will adversely affect the sound of the speaker.

Once the grilles and flange are painted and dry, replace the under-grille cloth, remove the paint plug from the speaker flange and install the grille.

Speaker Adjustments

Pivoting Woofer and Tweeter

All Original Series Medium Round speakers have a pivoting woofer assembly. The pivoting woofer-tweeter assembly is available on Original Series Medium Round 625R, 624R, 623R, 622R and 621R speakers. The 3-position tweeter adjustment switch is available on the 625R, 624R, 623R, and 623R TL speaker and lets you balance the speaker's high-frequency energy better to compliment the room's setup and acoustics. These pivoting drivers allow you to direct sound toward or away from the listening area.

If you're using the speakers in stereo or as the front L/C/R speakers in a home theater, pivot the woofer and/or tweeter directly towards the listening area. This can be especially helpful if the speakers are widely-separated and the music fails to blend into a central sonic image.

If you're using the speakers as surround channel speakers in a home theater, you can create a more diffuse, spacious surround effect by aiming the woofers and/or tweeter towards a wall or window, away from the listeners.

To pivot the woofer:

1. Apply pressure on the outer edge of the tweeter support bracket, as shown below in Figure 5. Do not touch or apply pressure to the woofer cone.

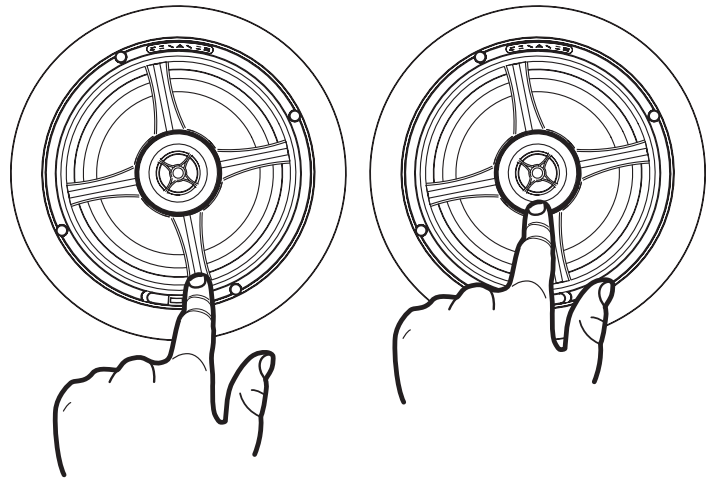

Figure 5: Pivoting the woofer and tweeter

Tweeter Level Control

The Original Series 625R, 624R, 623R, and 623R TL speakers feature a tweeter level control switch (see Figure 6) that lets you boost or cut the tweeter's level by 3dB. This allows you to adjust the speaker's brightness to better match your listening room or personal taste.

Once you have installed the speakers, listen to a variety of music that you are familiar with. If the music all tends to sound too bright or dull, use the Tweeter Level Control to compensate. If some recordings sound dull and some sound bright the speaker is accurately reproducing differences in the recordings, and you should leave the control in the middle (0dB) position.

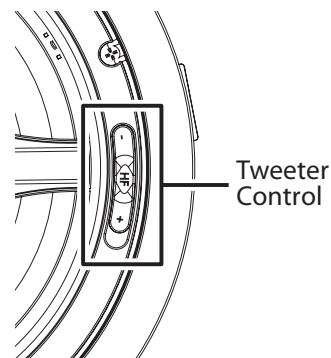

Figure 6: Tweeter level control

ORIGINAL SERIES MEDIUM ROUND SPEAKERS

Specifications

625R		
Tweeter:	1" (25mm) Beryllium dome, Ferrofluid-cooled, pivoting	
Woofers:	6½" (165mm) Beryllium cone, rubber surround, pivoting	
Frequency Response:	40Hz – 20kHz ±3dB	
Impedance:	6 Ohms nominal; 4 Ohms minimum	
Power Handling:	5 watts minimum; 150 Watts maximum	
Sensitivity:	90dB SPL (2.83V 1 meter)	
Grill Material:	Perforated aluminum	
Adjustments:	±3dB Tweeter level	
Dimensions (Dia. x Depth):	9¾" (248mm) x 4¾" (121mm)	
Cutout Diameter:	8¼" (210mm)	
Shipping Weight:	12 lbs. (5.45kg) Pair	
624R		
Tweeter:	1" (25mm) Aluminum dome, Ferrofluid-cooled, pivoting	
Woofers:	6½" (165mm) Coated carbon fiber cone, rubber surround, pivoting	
Frequency Response:	43Hz – 20kHz ± 3dB	
Impedance:	6 Ohms nominal; 4 Ohms minimum	
Power Handling:	5 watts minimum; 140 Watts maximum	
Sensitivity:	90dB SPL (2.83V 1 meter)	
Grill Material:	Perforated aluminum	
Adjustments:	±3dB Tweeter level	
Dimensions (Dia. x Depth):	9¾" (248mm) x 4¾" (121mm)	
Cutout Diameter:	8¼" (210mm)	
Shipping Weight:	11 lbs. (5.0kg) Pair	
623R		
Tweeter:	1" (25mm) Silk dome, Ferrofluid-cooled, pivoting	
Woofers:	6½" (165mm) Carbon fiber cone, rubber surround, pivoting	
Frequency Response:	43Hz – 20kHz ±3dB	
Impedance:	8 Ohms nominal; 6 Ohms minimum	
Power Handling:	5 watts minimum; 135 Watts maximum	
Sensitivity:	90dB SPL (2.83V 1 meter)	
Grill Material:	Perforated aluminum	
Adjustments:	±3dB Tweeter level	
Dimensions (Dia. x Depth):	9¾" x 4¾" (248mm x 121mm)	
Cutout Diameter:	8¼" (210mm)	
Shipping Weight:	10 lbs. (4.5kg) Pair	
622R		
Tweeter:	1" (25mm) Silk dome, Ferrofluid-cooled, pivoting	
Woofers:	6½" (165mm) polypropylene cone, rubber surround, pivoting	
Frequency Response:	45Hz-20kHz ± 3dB	
Impedance:	8 ohms nominal; 6 ohms minimum	
Power Handling:	5 watts minimum; 125 watts maximum	
Sensitivity:	89dB (2.83V/1 meter)	
Grille Material:	Perforated aluminum	
Adjustments:	None	
Dimensions (Dia. x Depth):	9¾" x 3" (248mm x 76mm)	
Cutout Diameter:	8¼" (210mm)	
Shipping Weight:	10 lbs (4.5kg) pair	
621R		
Tweeter:	¾" (19mm) Silk dome, Ferrofluid-cooled	
Woofers:	6½" (165mm) Polypropylene cone, rubber surround, pivoting	
Frequency Response:	50Hz – 20kHz ±3dB	
Impedance:	8 Ohms nominal; 6 Ohms minimum	
Power Handling:	5 watts minimum; 100 Watts maximum	
Sensitivity:	88dB SPL (2.83V 1 meter)	
Grill Material:	Perforated aluminum	
Adjustments:	None	
Dimensions (Dia. x Depth):	9¾" (248mm) x 4¾" (121mm)	
Cutout Diameter:	8¼" (210mm)	
Shipping Weight:	9 lbs. (4.1kg) Pair	
623R TL		
Tweeter:	1" (25mm) silk dome, ferrofluid cooled, pivoting	
Woofers:	6½" (165mm) carbon fiber cone, rubber surround, pivoting	
Frequency Response:	43Hz-20kHz ±3dB	
Impedance:	8 ohms nominal; 6 ohms minimum	
Power Handling:	5 watts minimum; 135 watts maximum	
Sensitivity:	90dB (2.83V/1 meter)	
Grille:	Perforated aluminum	
Adjustments:	±3dB Tweeter level	
Dimensions (Dia. x Depth):	9¾" x 3" (248mm x 76mm)	
Cutout Diameter:	8¼" (210mm)	
Shipping Weight:	10 lbs (4.5kg) pair	
622R TL		
Tweeter:	1" (25mm) silk dome, ferrofluid cooled, pivoting	
Woofers:	6½" (165mm) polypropylene cone, rubber surround, pivoting	
Frequency Response:	45Hz-20kHz ± 3dB	
Impedance:	8 ohms nominal; 6 ohms minimum	
Power Handling:	5 watts minimum; 125 watts maximum	
Sensitivity:	89dB (2.83V/1 meter)	
Grille Material:	Perforated aluminum	
Adjustments:	None	
Dimensions (Dia. x Depth):	9¾" x 3" (248mm x 76mm)	
Cutout Diameter:	8¼" (210mm)	
Shipping Weight:	10 lbs (4.5kg) pair	
621R TL		
Tweeter:	¾" (19mm) silk dome, ferrofluid cooled	
Woofers:	6½" (165mm) polypropylene cone, rubber surround	
Frequency Response:	50Hz-20kHz ±3dB	
Impedance:	8 ohms nominal; 6 ohms minimum	
Power Handling:	5 watts minimum; 100 watts maximum	
Sensitivity:	88dB (2.83V/1 meter)	
Grille Material:	Perforated aluminum	
Adjustments:	None	
Dimensions (Dia. x Depth):	9¾" x 3" (248mm x 76mm)	
Cutout Diameter:	8¼" (210mm)	
Shipping Weight:	9 lbs (4.1kg) pair	

Technical Assistance and Service

If you any have questions about the operation or installation of this product, please call our technical assistance department on any business day at (800) 582-0772 or (949) 492-7777; from 7 a.m. to 5 p.m., PST.

If your speakers should need repair or service, contact your Sonance Authorized Dealer for help, or use the following procedure:

1. Prior to calling, note the product's model number, serial number, purchase date, and the name and address of the dealer where you purchased the product.
2. Contact our Technical Assistance Department at the above number(s) and describe the problem the unit is experiencing. If applicable, they will issue a Return Authorization Number.

IMPORTANT: YOU MUST HAVE PRIOR AUTHORIZATION TO RETURN YOUR SPEAKER TO SONANCE!

3. If you're directed to return the unit to Sonance for repair, pack the unit in its original shipping carton. If needed, you can obtain replacement packaging from us for a small charge. Note: it is best if you place the box into an additional outer "overcarton" before shipment to minimize a chance of theft in shipment. Please include a copy of the original bill of sale inside the package.
4. Contact a package delivery company such as United Parcel Service or Federal Express to arrange prepaid (not collect) shipping. Do not use the U.S. Postal Service.

IMPORTANT: FREIGHT COLLECT SHIPMENTS WILL BE REFUSED.

5. Write the Return Authorization Number on the outside of the shipping carton.
6. Ship the packaged unit to:
Quality Assurance Department
Sonance
212 Avenida Fabricante
San Clemente, CA 92672-7531

ORIGINAL SERIES MEDIUM ROUND SPEAKERS

LIMITED LIFETIME WARRANTY

Sonance warrants to the first end-user purchaser that this Sonance-brand product ("Product"), when purchased from an authorized Sonance Dealer/Distributor, will be free from defective workmanship and materials for the life of the Product. Sonance will at its option and expense either repair the defect or replace the Product with a new or remanufactured Product or a reasonable equivalent.

EXCLUSIONS

TO THE EXTENT PERMITTED BY LAW, THE WARRANTY SET FORTH ABOVE IS IN LIEU OF, AND EXCLUSIVE OF, ALL OTHER WARRANTIES, EXPRESS OR IMPLIED, AND IS THE SOLE AND EXCLUSIVE WARRANTY PROVIDED BY SONANCE. ALL OTHER EXPRESS AND IMPLIED WARRANTIES, INCLUDING THE IMPLIED WARRANTIES OF MERCHANTABILITY, IMPLIED WARRANTY OF FITNESS FOR USE, AND IMPLIED WARRANTY OF FITNESS FOR A PARTICULAR PURPOSE ARE SPECIFICALLY EXCLUDED. No one is authorized to make or modify any warranties on behalf of Sonance.

The warranty stated above is the sole and exclusive remedy and Sonance's performance shall constitute full and final satisfaction of all obligations, liabilities and claims with respect to the Product. IN ANY EVENT, SONANCE SHALL NOT BE LIABLE FOR CONSEQUENTIAL, INCIDENTAL, ECONOMIC, PROPERTY, BODILY INJURY, OR PERSONAL INJURY DAMAGES ARISING FROM THE PRODUCT, ANY BREACH OF THIS WARRANTY OR OTHERWISE.

This warranty statement gives you specific legal rights, and you may have other rights which vary from state to state. Some states do not allow the exclusion of implied warranties or limitations of remedies, so the above exclusions and limitations may not apply. If your state does not allow disclaimer of implied warranties, the duration of such implied warranties is limited to period of Sonance's express warranty.

Your Product Model and Description: Original Series Medium Round Speaker

Additional Limitations and Exclusions from Warranty Coverage: The warranty described above is non-transferable, applies only to the initial installation of the Product, does not include installation of any repaired or replaced Product, does not include damage to allied or associated equipment which may result for any reason from use with this Product, and does not include labor or parts caused by accident, disaster, negligence, improper installation, misuse (e.g. overdriving the amplifier or speaker, excessive heat or cold or humidity, outdoor installation), or from service or repair which has not been authorized by Sonance.

Obtaining Authorized Service: To qualify for the warranty, you must (1) contact your authorized Sonance Dealer/Installer or call Sonance Customer Service at (800) 582-0772 within the warranty period, (2) obtain a return merchandise number (RMA), and (3) deliver the Product to Sonance shipping prepaid during the warranty period, together with the original sales receipt, invoice or other satisfactory proof of purchase.



SONANCE®

©2010 Sonance. All rights reserved.

Sonance, FastMount, and Roto-Lock are registered trademarks of Dana Innovations.

Due to continuous product improvement, all features and specifications are subject to change without notice.

For the latest Sonance product specification information visit our website: www.sonance.com

SONANCE • 212 Avenida Fabricante • San Clemente, CA 92672-7531 USA

(800) 582-7777 or (949) 492-7777 • FAX: (949) 361-5151 • Technical Support: (800) 582-0772

www.sonance.com

33-5481 Rev. 10/2010