

INSTRUCTION MANUAL

VISUAL PERFORMANCE® SERIES MEDIUM RECTANGLE SPEAKERS



Introduction

Thank you for purchasing Sonance Visual Performance® Series Medium rectangle speakers. When properly installed your new speakers will give you years of entertainment pleasure.

SAFETY WARNING:

THESE SPEAKERS HAVE FASTMOUNT® TABS THAT PREVENT THE SPEAKER FROM FALLING OUT OF THE MOUNTING HOLE DURING THE INSTALLATION PROCESS.

THE EDGES OF THE FASTMOUNT TABS ARE VERY SHARP. USE CAUTION WHEN HANDLING THE SPEAKER.

Box Contents

Each Sonance Visual Performance Series Medium rectangle speaker box contains (2) Visual Performance Series speakers, (2) paint plugs (installed on the fronts of the speakers), (2) paintable grilles and (1) mounting cut-out template.

Speaker Placement

Home Theater Speaker Placement

Left, Center & Right Speakers

- Place the left & right speakers on either side of the video screen, 6 – 10 feet (1.8m – 3m) apart and 3 – 4 feet (0.9m – 1.2m) from the floor.
- If possible, locate the center speaker at the same height as the left & right channel speakers.
- If you must place the center speaker above or below a video screen, place it no more than 2 feet (0.6m) above or below the center of the left and right speakers. This will maintain consistent tonality between all three front channel speakers.
- The main listening position should be 8 – 12 feet (2.4m – 3.7m) away from the speakers.

Use *Figure 1* as a guide.

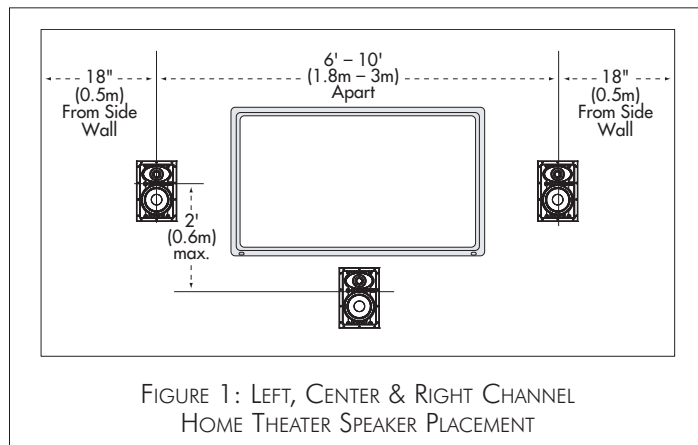
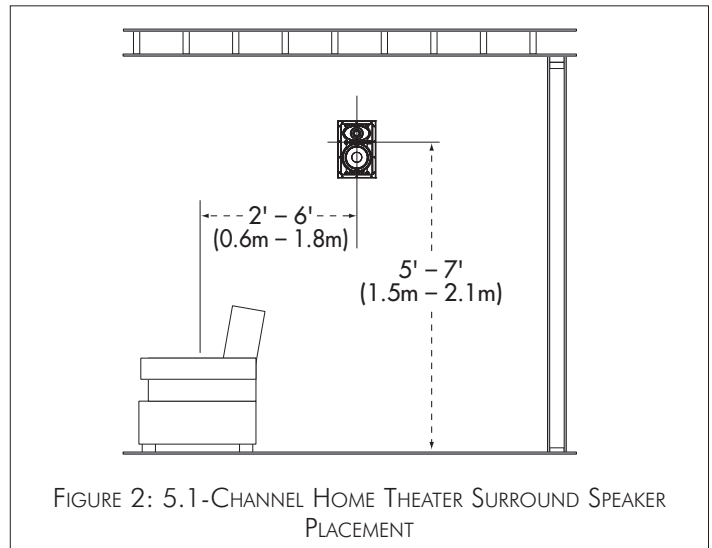

FIGURE 1: LEFT, CENTER & RIGHT CHANNEL HOME THEATER SPEAKER PLACEMENT

Surround Speakers (5.1-Channel System)

Locate the surround channel speakers on the side walls 2 – 6 feet (0.6m – 1.8m) behind the listening position, 5 – 7 feet (1.5m – 2.1m) from the floor. Use *Figure 2* as a guide.



Surround Speakers (7.1-Channel System)

- LEFT & RIGHT SURROUND SPEAKERS:** Place the left and right surround speakers directly to the sides of the listening position, at least 5 feet from the floor.
- SURROUND BACK SPEAKERS:** Place the surround back speakers in the rear wall, 3 – 6 feet (0.9m – 1.8m) apart and 5 – 7 feet (1.5m – 2.1m) from the floor.

Use *Figure 3* as a guide.

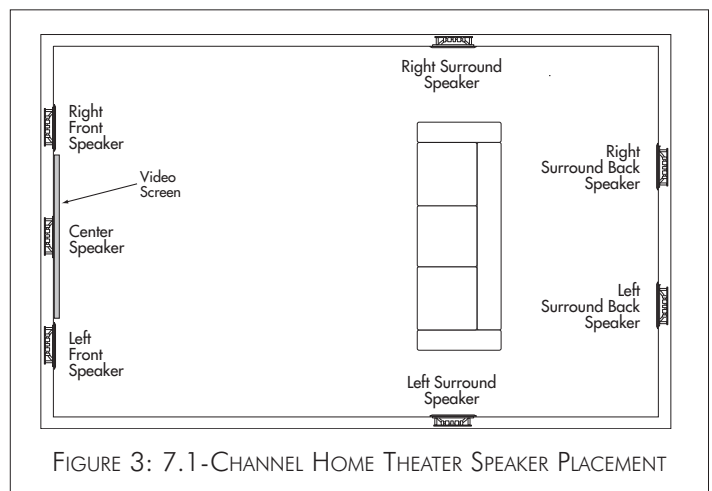

FIGURE 3: 7.1-CHANNEL HOME THEATER SPEAKER PLACEMENT

Stereo (2-Channel) Placement

- Place the left and right speakers 6 – 10 feet (1.8m – 3m) apart, with the main listening position as close to midway between the speakers as possible.
- The speakers should be at least 2 feet (0.6m) away from the side walls.
- The main listening position should be 4 – 10 feet (1.2m – 3m) away from the speakers.
- In most cases pivoting the tweeter of each speaker directly towards the main listening position will help maximize the stereo soundstage.

Use the left and right speaker placement in *Figure 1*, on page 1, as a guide.

Before Installation: Retrofit

1. Determine the location for the speaker (see *Speaker Placement* on page 1).
2. Perform an obstruction survey to be certain that there are no studs, conduit, pipes, heating ducts, pocket doors or air returns in the wall cavity that will interfere with the speaker.
3. **Mounting space requirements:** 6¹⁵/₁₆" (176mm) wide by 10³/₄" (273mm) high cut-out and at least 3¹/₂" (89mm) mounting depth. Medium ThinLine rectangle speakers require at least 2¹/₂" (64mm) mounting depth.
4. Position the included cut-out template where the speaker is to be located and pencil an outline on the wall. If you are unsure about obstructions, drill a small hole in the center of the outline and insert a coat hanger wire into the hole to feel-around for possible obstructions.
5. Cut the mounting hole using a keyhole or drywall saw, and run the speaker wires from the mounting hole to the amplifier location.

NOTE: CONSULT LOCAL BUILDING CODES BEFORE RUNNING SPEAKER WIRES THROUGH WALLS.

Before Installation: IR Plug

Sonance Visual Performance Series Medium rectangle speakers have a plug for installing an IR receiver into the speaker's front baffle (see *Figure 4*). In systems where the electronics are placed in an inconvenient location this allows remote controls to be aimed at the front of the room instead of at the electronics.

The IR plug is in the form of a bolt and retaining nut. To remove the plug, unscrew the nut (located behind the baffle, see *Figure 5*) and remove the bolt. The hole is designed to receive a Sonance OptiLinQ® SMR1 or SMR1P Surface-Mount IR receiver. Insert the IR receiver through the front of the speaker baffle and use the nut included with the receiver to secure it to the baffle.

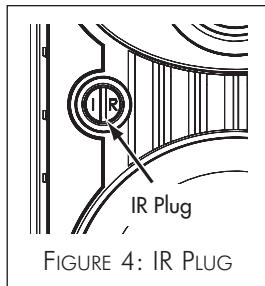

FIGURE 4: IR PLUG

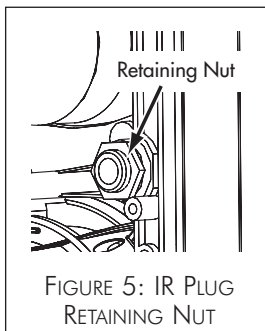

FIGURE 5: IR PLUG RETAINING NUT

Installation

Sonance Visual Performance Series speakers feature exclusive FastMount tabs and an integral Roto-Lock® mounting system for quick mounting directly into existing walls.

WARNING: THE EDGES OF THE FASTMOUNT TABS ARE VERY SHARP. USE CAUTION WHEN HANDLING THE SPEAKER.

1. Remove the paint plug from the speaker.
2. Strip 1/4" – 1/2" (6mm – 12mm) of insulation from each speaker lead. Twist the strands or tin the exposed wire with solder to ensure that there are no stray strands. (Stray strands that touch each other can cause a short-circuit that can damage the amplifier.)
3. The speaker's connector posts are spring-loaded. Push the top of each connector post down to open the connector and insert the exposed wires into the holes in the posts.

The speaker's positive post is labeled with a red dot; the negative post is labeled with a black dot. Double-check that you connected amplifier "+" to speaker "+" and amplifier "-" to speaker "-".

4. Make sure all the Roto-Lock clamps are retracted so that they are tucked within the mounting hole's border. Insert the speaker into the hole in the wall (*Figure 6*). The Roto-Lock system can accommodate a maximum wall material thickness of 1 1/4" (32mm).

The FastMount tabs will prevent the speaker from falling out of the mounting hole, allowing you to let go of the speaker to pick-up tools or other items (*Figure 7*).

NOTE: THE FASTMOUNT TABS ARE DESIGNED FOR ONE-TIME USE ONLY. IF THE SPEAKER IS REMOVED FROM THE MOUNTING HOLE THE FASTMOUNT TABS WILL DISCONNECT AND REMAIN INSIDE THE WALL.

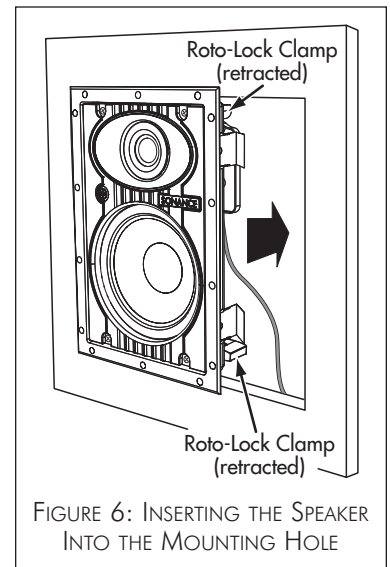

FIGURE 6: INSERTING THE SPEAKER INTO THE MOUNTING HOLE

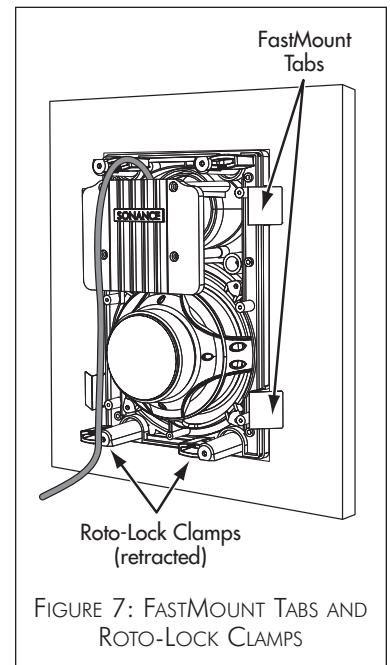

FIGURE 7: FASTMOUNT TABS AND ROTO-LOCK CLAMPS

SONANCE VISUAL PERFORMANCE® MEDIUM RECTANGLE

5. Tighten the four screws on the front of the speaker baffle. The RotoLock clamps will automatically rotate into position and begin clamping the speaker (*Figure 8*).

When you notice resistance on the screws the speaker has been clamped successfully.

IMPORTANT: Always use low-torque settings; NEVER over-tighten.

NOTE: ADJUSTING THE TENSION OF THE ROTOLock CLAMPS SO THAT THE SPEAKER FRAME IS FLAT WILL HELP ENSURE THAT THE GRILLE CONTACTS THE WALL ALL THE WAY AROUND THE SPEAKER FOR A PROPER FIT.

6. The new micro-trim grille is held in place by several small, powerful magnets on the speaker frame. Place the grille against the speaker and the magnets will hold it firmly in place. When properly installed, the grille trim should make contact with the wall all the way around the speaker.

Painting the Grilles

Please refer to the accompanying *Painting Instructions* sheet for painting instructions.

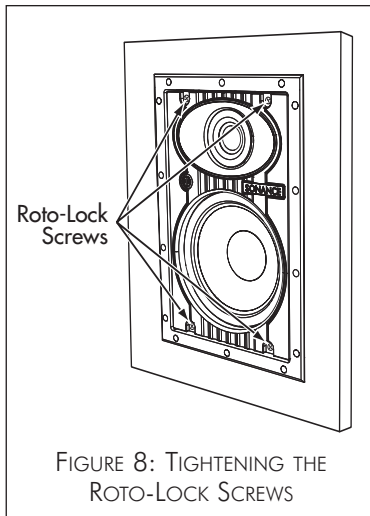

FIGURE 8: TIGHTENING THE ROTO-LOCK SCREWS

Speaker Adjustments

Pivoting Tweeter

All Visual Performance Series in-wall speakers have a pivoting tweeter that allows you to direct sound towards or away from the listening area, depending on how the speakers are being used:

- If you're using the speakers in stereo or as the front left/center/right speakers in a home theater, pivot the tweeter directly towards the listening area. This will help the sound from the speakers blend into a solid soundstage even if the speakers are widely separated.
- If you're using the speakers as surround channel speakers in a home theater, you can create a more diffuse, spacious surround effect by pivoting the tweeter towards a wall or window, away from the listeners.

To pivot the tweeter, apply light pressure to the plastic ring around the outside edge of the tweeter dome, as shown in *Figure 9*. Take care not to touch or apply pressure to the tweeter dome itself.

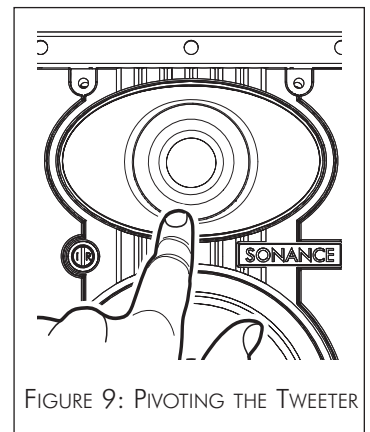

FIGURE 9: PIVOTING THE TWEETER

LIMITED LIFETIME WARRANTY

Sonance warrants to the first end-user purchaser that this Sonance-brand product ("Product"), when purchased from an authorized Sonance Dealer/Distributor, will be free from defective workmanship and materials for the life of the Product, except for the grille, which is warranted for five (5) years. Sonance will at its option and expense either repair the defect or replace the Product with a new or remanufactured Product or a reasonable equivalent.

EXCLUSIONS

TO THE EXTENT PERMITTED BY LAW, THE WARRANTY SET FORTH ABOVE IS IN LIEU OF, AND EXCLUSIVE OF, ALL OTHER WARRANTIES, EXPRESS OR IMPLIED, AND IS THE SOLE AND EXCLUSIVE WARRANTY PROVIDED BY SONANCE. ALL OTHER EXPRESS AND IMPLIED WARRANTIES, INCLUDING THE IMPLIED WARRANTIES OF MERCHANTABILITY, IMPLIED WARRANTY OF FITNESS FOR USE, AND IMPLIED WARRANTY OF FITNESS FOR A PARTICULAR PURPOSE ARE SPECIFICALLY EXCLUDED. No one is authorized to make or modify any warranties on behalf of Sonance.

The warranty stated above is the sole and exclusive remedy and Sonance's performance shall constitute full and final satisfaction of all obligations, liabilities and claims with respect to the Product. IN ANY EVENT, SONANCE SHALL NOT BE LIABLE FOR CONSEQUENTIAL, INCIDENTAL, ECONOMIC, PROPERTY, BODILY INJURY, OR PERSONAL INJURY DAMAGES ARISING FROM THE PRODUCT, ANY BREACH OF THIS WARRANTY OR OTHERWISE.

This warranty statement gives you specific legal rights, and you may have other rights which vary from state to state. Some states do not allow the exclusion of implied warranties or limitations of remedies, so the above exclusions and limitations may not apply. If your state does not allow disclaimer of implied warranties, the duration of such implied warranties is limited to period of Sonance's express warranty.

Your Product Model and Description: Sonance Visual Performance Series Medium Rectangle Speakers

Additional Limitations and Exclusions from Warranty Coverage: The warranty described above is non-transferable, applies only to the initial installation of the Product, does not include installation of any repaired or replaced Product, does not include damage to allied or associated equipment which may result for any reason from use with this Product, and does not include labor or parts caused by accident, disaster, negligence, improper installation, misuse (e.g. overdriving the amplifier or speaker, excessive heat or cold or humidity, outdoor installation), or from service or repair which has not been authorized by Sonance.

Obtaining Authorized Service: To qualify for the warranty, you must contact your authorized Sonance Dealer/Installer or call Sonance Customer Service at (800) 582-0772, must obtain a return merchandise number (RMA), and must deliver the Product to Sonance shipping prepaid during the warranty period, together with the original sales receipt, or invoice or other satisfactory proof of purchase.



©2009 Sonance. All rights reserved.

Sonance, Visual Performance, FastMount, Roto-Lock and OptiLinQ are registered trademarks of Dana Innovations.

Due to continuous product improvement, all features and specifications are subject to change without notice.

For the latest Sonance product specification information visit our website: www.sonance.com

SONANCE • 212 Avenida Fabricante • San Clemente, CA 92672-7531 USA

(800) 582-7777 or (949) 492-7777 • FAX: (949) 361-5151 • Technical Support: (800) 582-0772